

Sustainable Management of Surfing Breaks: Case Studies and Recommendations

Bradley E. Scarfe[†], Terry R. Healy[‡], Hamish G. Rennie[‡], and Shaw T. Mead[§]

[†]University of Waikato
Private Bag 3105
Hamilton, New Zealand
brad@coasta.co.nz

[‡]Lincoln University
Department of Environment, Society and
Design
Lincoln University
P.O. Box 84
Lincoln, New Zealand

[§]ASR Ltd.
P.O. Box 67
Raglan, New Zealand

ABSTRACT

SCARFE, B.E.; HEALY, T.R.; RENNIE, H.G., and MEAD, S.T., 2009. Sustainable management of surfing breaks: case studies and recommendations. *Journal of Coastal Research*, 25(3), 684–703. West Palm Beach (Florida), ISSN 0749-0208.



Despite their large numbers worldwide, surfers as a coastal interest group have largely been ignored during coastal management decision making. Surfers are, however, increasingly being considered in coastal management decisions as the social, economic, and environmental benefits of high-quality surfing breaks are realized. Examples of surfing breaks that have been improved or compromised by coastal engineering are presented here to demonstrate the fragility of surfing breaks. Integrated coastal zone management techniques are suggested as an approach to sustain recreational amenities associated with surfing breaks. Surfers can benefit from integrated coastal zone management practices that balance the coastal space requirements of various coastal user groups. This paper advocates detailed and standardized assessments of the environmental impacts that coastal activities can have on the quality of surfing waves as part of modern integrated coastal zone management practices. Baseline information must also be collected to develop an understanding of the physical processes around a surfing break. To facilitate baseline studies, and ongoing monitoring of surfing breaks, this paper identifies the types of surfing and oceanographic factors that need to be considered. The need for regional and central governments to strategically protect surfing breaks using legislation, reserves, and coastal management plans is explored. It is recommended that further surfing research investigate ideal coastal management techniques for different resource management frameworks.

ADDITIONAL INDEX WORDS: *Surfing reefs, coastal space, recreational space, coastal amenities, integrated coastal management (ICM), environmental impact assessment (EIA), geographic information system (GIS), coastal engineering, wave focusing, coastal development.*

INTRODUCTION

In a detailed analysis, Small and Nicholls (2003) found that the coastal population is approximately three times the global average and that it is commonly believed that coastal migration is continuing and growing. Lazarow (2007) estimates that 86% of Australians live within 30 minutes of the coast, while in small island nations the entire population is coastal. Development to support growing coastal populations puts pressure on many resources, including the natural features that create surfing waves (e.g., Anonymous, 2003; Lazarow, 2007; Mead *et al.*, 2007; Pratte, 1987). It is asserted by this paper that the features that form a surfing break are a resource that possesses recreational amenity values. Surfing breaks need protection as these amenity values are important resources for coastal communities, both socially and economically (Lazarow, 2007; Lazarow, Miller, and Blackwell, 2007a, 2007b; Nelsen, Pendleton, and Vaughn, 2007). Some environmental legislation, e.g., New Zealand's Resource Management Act (1991, Section 7c) already requires the protection and maintenance of these recreational amenity values.

Not all surfing breaks are entirely natural. They can be created, modified, or destroyed by human activities such as the construction of seawalls (e.g., Saint Clair, Dunedin, New Zealand), jetties (e.g., Mission Bay jetties, San Diego, California), boating infrastructure (e.g., Manu Bay, Raglan, New Zealand), piers (e.g., Oil Piers, Ventura, California), and beach nourishment (e.g., "The Cove" Sandy Hook, New Jersey). It is not surprising that many existing surfing breaks are unnatural because there are few environments that have not been impacted to some degree by human activity. Whether or not the environmental impact is favorable, the environment possesses some degree of artificiality after the alteration (French, 1997). While the engineering effects can be positive on surfing wave quality (e.g., The Superbank, Gold Coast, Australia), more often the surfing breaks are compromised (e.g., Saint Clair, Dunedin, New Zealand) or even destroyed (e.g., El Segundo, California). Discussions on this issue are rare in coastal literature (e.g., Benedet, Pierro, and Henriquez, 2007).

The main purpose of this paper is to demonstrate the need to sustainably manage surfing amenities using detailed studies of physical processes and to recommend coastal management methods for surfing breaks. Social research such as

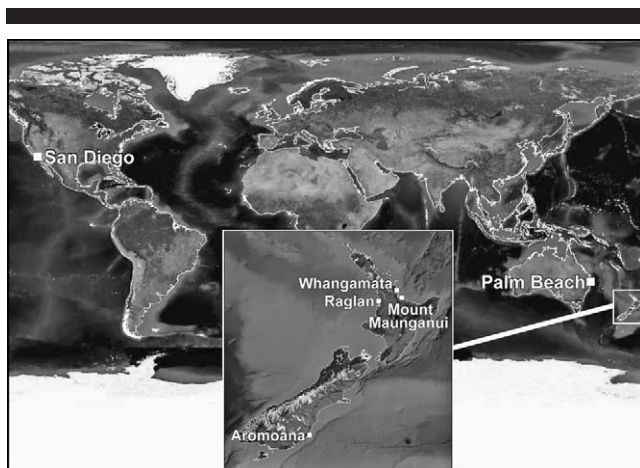

Figure 1. Location of case studies of surfing and coastal management discussed in this research.

monitoring changes in surfing break usage (e.g., counting surfer numbers) and surfer demographics are also important but are outside of the scope of this work. Other issues central to surfers but not covered in this research include water quality and amenities such as car parks, showers, clubrooms, and beach access. This research is primarily focused on the oceanographic processes that cause surfing waves to form and activities that are likely to affect the “surfability” (Dally, 1989; Hutt, Black, and Mead, 2001; Mack, 2003; Walker, 1974). This paper forms part of a larger research effort by Scarfe (2008) focused on developing methods for the oceanographic management of surfing amenities. The following specific tasks are undertaken in this paper:

- A review of examples of development around surfing breaks to highlight the effects coastal engineering can have on surfing breaks
- An exploration of the use of integrated coastal zone management (ICZM) techniques to maximize surfing amenities

CASE STUDIES OF SURFING AND DEVELOPMENT

Every year surfing breaks are compromised by coastal engineering projects that do not consider impacts to surfing. This is not surprising as there is a lack of dedicated publications on the subject (Scarfe, Healy, and Rennie, 2009). A few non-peer-reviewed publications on surfing break protection are available (e.g., Mead, Black, and Scarfe, 2004; Nelsen and Howd, 1996), but it is still a new area of coastal research. For example, a conference paper by Pratte (1987) overviews the problem of surfing breaks and coastal development, and technical reports (Black, Hutt, and Mead, 1998; Scarfe *et al.*, 2003b) investigated physical effects that boat infrastructure has on surfing breaks.

In a reviewed article on the topic, Lazarow (2007) investigates the economic value of surfing breaks, as well as conflicts between surfing and other coastal activities. The topic is further investigated by Lazarow, Miller, and Blackwell (2007a, 2007b) and Nelsen, Pendleton, and Vaughn (2007),

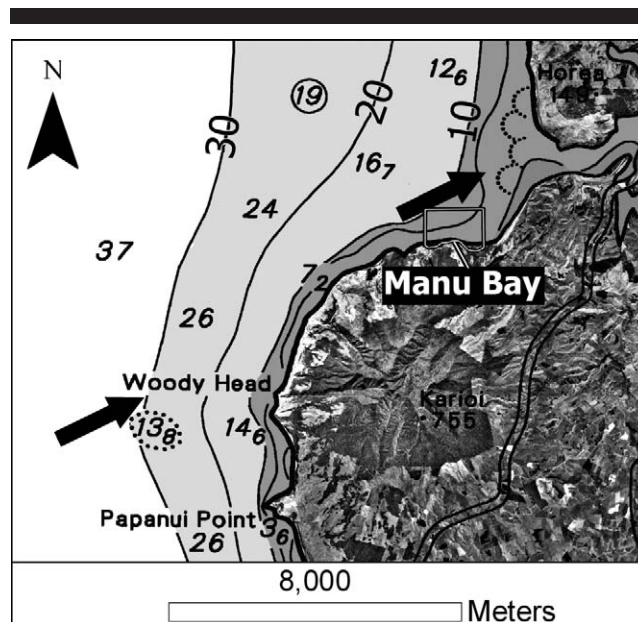

Figure 2. Raglan headland with aerial photography and navigational chart adapted from data from Land Information New Zealand. The arrows represent the average of 28 years (1979–2007) of mean wave directions at 40 m and 11 m depths. The coverage of the 2001 survey of Manu Bay (Figure 5) is included on this figure.

who provide useful discussions and methods for coastal managers. Oceanographic processes important for surfing are not discussed in these publications, yet these processes are a necessary consideration to successfully include surfing in coastal management. Another discussion by Farmer and Short (2007) noted that despite the rapid growth in the number of Australian surfers and the size of the surfing industry, little has been done to protect the surfing breaks. They have rekindled interest in surfing reserves as a coastal management technique. The first surfing reserve in Australia was created in 1973, but in 2005 only one of Australia’s more than 10,000 beaches was a dedicated surfing reserve. Presently there are 4 reserves, with another 24 proposed (Farmer and Short, 2007). The reserves are gazetted by the Department of Lands as a reserve, and the boundary extends from the high water mark to 500 m seaward. The reserve is managed by a board of representatives of the surfing area. Buckley (2002a, 2002b) also discusses surfing and management issues, with a focus on tourism and surfing in Indonesia.

To further contribute to the topic of surfing and coastal management, this work presents six case studies (Figure 1) highlighting the potential oceanographic effects that coastal engineering can have on surfing breaks.

Case Study 1: Manu Bay Boat Ramp, Raglan (New Zealand)

Some of New Zealand’s most iconic and extensively studied surfing breaks are on the north end of the Raglan headland (Figure 2; Hutt, 1997; Mead, 2001; Mead and Phillips, 2007; Moores, 2001; Phillips, 2004; Scarfe, 2002a; Shand *et al.*,

Table 1. Average value of wave parameters for 1979–2007 from modeling data by Gorman and colleagues (Gorman, 2005; Gorman, Bryan, and Laing, 2003a, 2003b).

Parameter	Depth 100 m		Depth 40 m		Depth 11 m	
	Average	Standard Deviation	Average	Standard Deviation	Average	Standard Deviation
Significant wave height (m)	1.80	0.81	1.61	0.77	1.60	0.76
Mean period (s)	6.9	1.2	7.2	1.3	7.4	1.3
Mean direction (TO, ° CW from N)	61.8	18.9	66.9	17.4	68.3	17.4
Peak direction (TO, ° CW from N)	58.6	14.5	59.4	14.5	59.7	13.8
Peak period (s)	11.4	2.4	11.5	2.3	11.5	2.2
Directional spread (°)	31.8	11.2	27.0	7.9	25.6	7.5
Spectral width	0.531	0.082	0.543	0.083	0.527	0.078

* CW from N = the angle is clockwise from north and describes the direction waves travel toward.

2007). When oceanographic conditions are suitable (Hutt, 1997; Scarfe, 2002a), surfing waves peel perfectly along the boulder and reef shoreline, creating seven surfing breaks. However, a small engineering structure has had a negative effect on the most easterly surfing break, called Manu Bay.

Manu Bay is a consistent surfing break that can be surfed in a range of conditions. The average of various wave parameters (Table 1) has been calculated from modeling data created by Gorman and colleagues, (Gorman, 2005; Gorman, Bryan, and Laing, 2003a, 2003b). As waves transform from the deep to shallow water, they are predicted to reduce in height and directional spread, as well as increase in mean direction, but not peak direction. Since surfers ride the largest waves in a set (Hutt, 1997), it is possible that these peak waves are most important to surfing studies. Although, near-shore wave focusing is not included in the model simulations,

the results still begin to describe how the wave character changes as the waves propagate from deep to shallow water.

The consistency of swell makes the estuary bar often impossible to navigate, requiring the construction of a breakwater and boat ramp at the end of the Manu Bay surfing break during the 1960s. Waves are smaller in the sheltered bay than farther south along the headland, making the boat ramp position a seemingly sensible location (Figure 3). However, the breakwater construction directly affects the end of the surfing ride during some high tide conditions, with further impacts to the natural current patterns, sedimentary morphology, and consequently, the surfing ride. The loss of ride length (and wave shape) was caused by two engineering activities. First, discussions with local residents and the council revealed that the shoreline reef was dredged, dynamited, or both. No actual records of the construction were found to exist. The second activity was the breakwater construction.

One of the most famous surfing films of the 1960s, *Endless Summer* (Bruce Brown Films, 1990), includes footage of Manu Bay before the boat ramp construction. Frames from the film were captured, enlarged, and enhanced using Topaz Moment version 3.2 software (Topaz Labs) and subsequently merged together. Although the film only shows one overview shot of Manu Bay (Figure 4), it is reasonably clear that the boulder shoreline that currently exists to the northwest of the

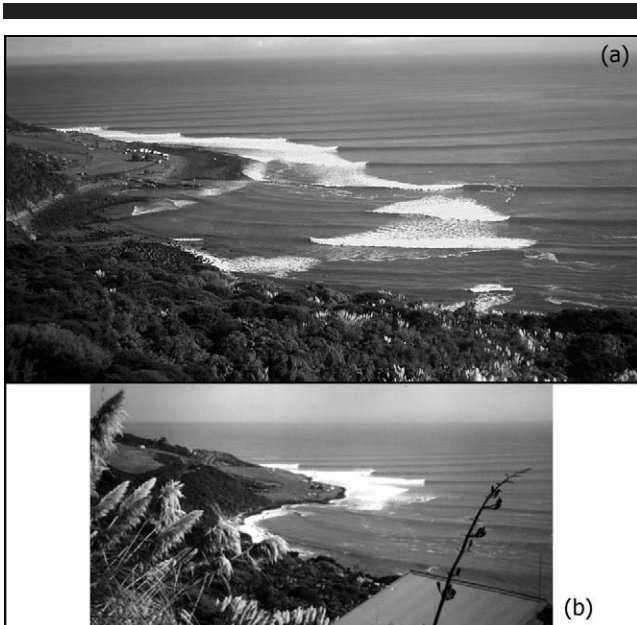

Figure 3. Oblique photos of the Manu Bay surfing break showing impact of the boat ramp on shoreline and wave breaking patterns: (a) 2001 high tide photo (Scarfe *et al.*, 2002), and (b) 2007 low tide photo (S. Stephens, personal communication). The areas of breaking and calm waves are important to the shoreline and seabed morphology, and hence to surfing conditions. For a color version of this figure, see page 667.

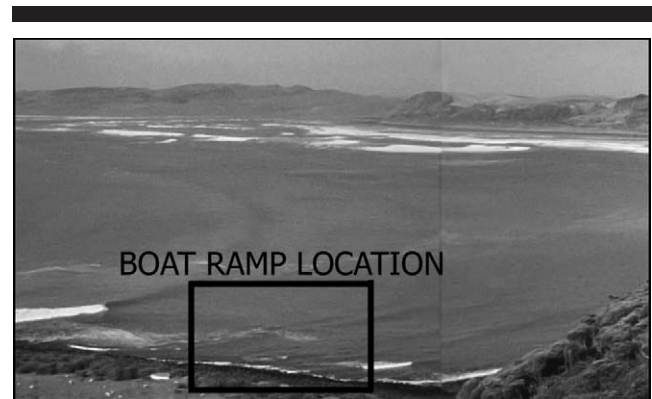

Figure 4. Video frames captured from the 1960s *Endless Summer* (Bruce Brown Films, 1990) showing the Manu Bay shoreline before the boat ramp construction. For a color version of this figure, see page 667.

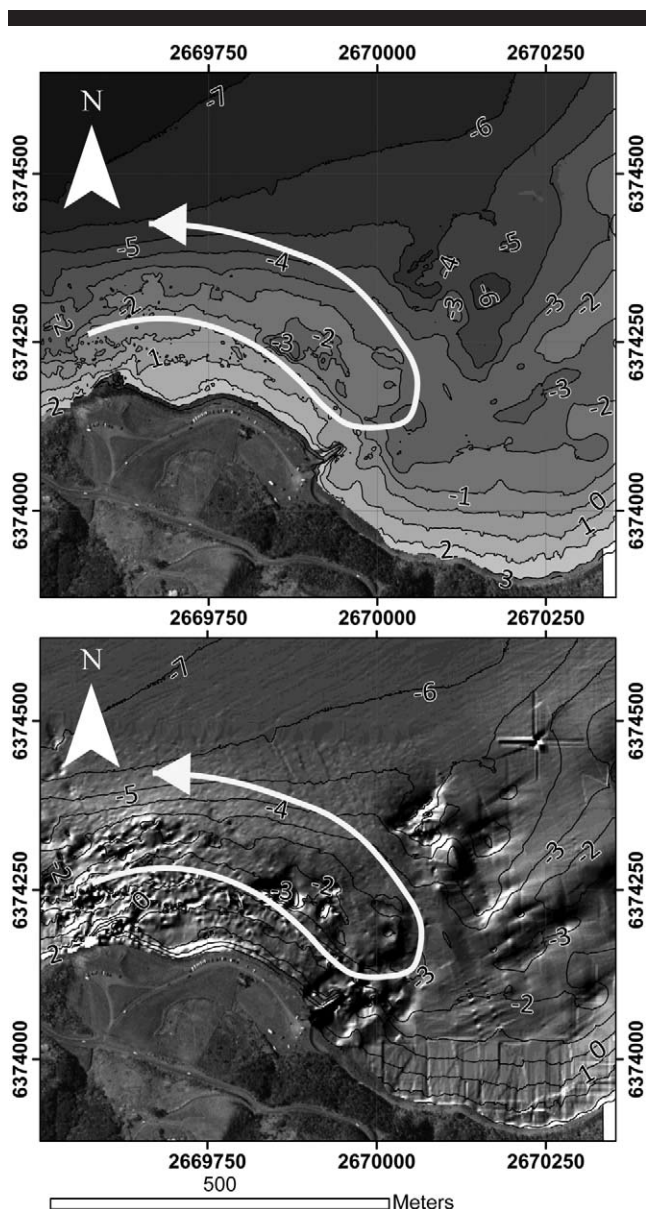

Figure 5. Bathymetry (top) and hillshade (bottom) of Manu Bay surfing break. The arrow represents the circulating current induced by wave processes and steered by bathymetric features. There are bathymetric depressions (holes) around and offshore of the breakwater. (Background aerial photography from Terralink International. Coordinates in New Zealand Map Grid, depths relative to chart datum [LAT].)

boat ramp was present at the current boat ramp position during the film. The image in Figure 4 only shows moderate-sized waves, which stop breaking around the boat ramp location, but during bigger swell events the surfing waves were likely to continue to peel past the current boat ramp position.

The configuration of surfing break components was initially discussed in Mead and Black (2001a, 2001b), and this type of analysis can be used to understand what has happened to the Manu Bay surfing break after the boat ramp development. Based on a hydrographic survey by Hutt (1997), Mead

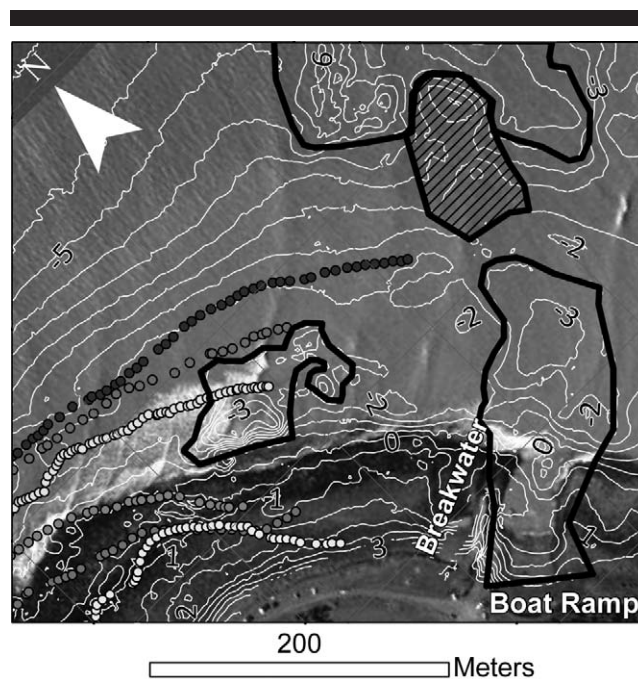

Figure 6. Bathymetric contours around boat ramp. The dark polygons show areas of deep water, with the striped polygon representing a shoal area. The dots represent the path of breaking surfing waves from Hutt (1997) during different stages of the tide. The deeper breaking waves are during low tide conditions, and the shallower breaking waves are during high tide. (Aerial photography of small nonsurfing waves from Terralink International, 2002. Depths relative to chart datum [LAT].) For a color version of this figure, see page 668.

and Black (2001b) identified the macroscale components of Manu Bay as a large wedge with a ridge that creates “The Ledge” surfing break. Scarfe (2002a) recharted the surfing break using more accurate methods (Scarfe, 2002b) to show further complexity in the reef and sand surfing break (Figure 5a). The hillshade diagram (Figure 5b) shows a consistent color where the seabed is smooth and sandy. Nearer the shore, the undulating reef has more variation in the shading. Various holes and mounds, enlarged in Figure 6, are also highlighted by the hillshading.

The ridge feature that causes the extreme wave breaking at “The Ledge” is relatively small, with a surface area of 3200 m², while the wave breaking component of the wedge (+1 to -2.5 m chart datum) is approximately 70,000 m². The main wedge is actually two wedge components separated by a platform. These wedges are the main wave breaking components, and they function differently during different swell events and tide levels due to the mesoscale tidal range (3.0 m spring). The two wedges are approximately 30,000 m² (shallow shelf/wedge) and 40,000 m² (deep shelf/wedge), and they allow surfing waves to peel along the contours. Considering the size of the ledge and wedges, the hole around the breakwater (5800 m²) and the hole immediately offshore (15,500 m²) are large features in comparison to the actual surfing break components, making them worthy of further investi-

gation during management of any issues relating to this surfing break.

Wave breakpoint measurements taken from aerial photographs by Hutt (1997) were calculated through the tidal cycle, and they are overlaid with the bathymetry from Scarfe (2002a) in Figure 6. The 1996 aerial photos were taken during a 1.2- to 1.5-m significant wave height (H_{sig}) swell event at six stages of the tide. The waves therefore only break a small way around the headland. Notice how the three higher tide measurements break on the upper wedge and the three lower tide measurements break on the lower wedge. The platform between the two wedge components is approximately 50 m wide in the offshore regions and expands to 80 m wide eastward, pushing the lower tide waves offshore. At the end of the path of the midtide breaking waves in the Hutt (1997) measurements, there is a 4-m-deep hole that modifies the wave and current patterns. The effects of the shelf and hole on wave transformations during low tide conditions are clear in Figure 3a. The platform pushes the breaking waves offshore, and the hole creates an area of calm water, with further impacts to current circulations.

In the net, 175,000 m³/y of sediment move around the Raglan surfing breaks (Phillips, 2004). This is made up of 275,000 m³/y in an easterly direction in the surf zone area and 100,000 m³/y to the west farther offshore in a recirculating sediment-current pathway. The westerly flow is generated by the interaction of wave-driven forces and bathymetric steering (Phillips, 2004). The width of the circulating cell was found by Phillips (2004) to vary with swell size and tide level. Large wave events at low tide generate the strongest currents flowing east along the headland. However, the strongest westerly currents were found when the tide is the highest. Considering the significant volume of sediment moving around the headland, any construction modifying currents (e.g., the breakwater and dredging) can cause morphological changes due to bathymetric steering of currents and impacts to surf zone hydrodynamics. During large swell conditions, strong wave-driven currents, which would normally flow down the headland unimpeded, are directed offshore by the breakwater and dredged boat ramp.

It is likely that the recirculating sediment pathways, measured and modeled by Phillips (2004), cause some erosion of the seabed in areas of strong currents (Figure 5). Although the mechanisms for the creation of the holes noted in Figure 6 cannot be resolved in this study, any modification to the currents by the dredging or breakwater potentially can change the seabed morphology some distance from the engineering. This point is iterated by Scarfe (2008). Since the largest hole identified in Figure 6 is directly perpendicular to the boat ramp and dredged area, it is likely that the engineering had some influence on hole formation. The shoal area just north of the breakwater hole could have been created as the currents slow and sediment drops out of suspension, similar to the way a delta is formed at an inlet.

In summary, the breakwater can affect the coastal processes and surfing in three possible ways: (i) directing the sand and smaller gravels offshore by the recirculating sediment pathways, reinforcing the hole to the north of the boat ramp breakwater; (ii) controlling the location of an eddy or

rip that erodes a hole in the sand and boulder wedge; and (iii) providing a structure that blocks natural wave and current movements around the headland. This first process has led to erosion of the boulder beach south of the boat ramp, and it is currently stabilized by a failing seawall.

Case Study 2: Palm Beach Reefs, Gold Coast (Australia)

Three large-scale offshore reefs were planned as coastal protection devices at Palm Beach, Gold Coast, Australia (Tomlinson *et al.*, 2003). Palm Beach is an important surfing area, with 3 of the top 10 professional surfers on the World Tour residing at Palm Beach in 2004 (Mead, Black, and Scarfe, 2004). Inevitably, potential impacts of the project on surfing amenities, poor public participation, and lack of alternative options led to a 1200-person protest on the beach. Although the reef project attempted to develop an integrated and multifunctional coastal management strategy (Tomlinson *et al.*, 2003), it is apparent that this was not the case, as such a large-scale protest would not occur if public consultation was adequate.

The environmental impact assessment (EIA) concluded that inshore surfing conditions would be unaffected by the presence of the three reefs along the beach, and surfing improvements were predicted by Tomlinson *et al.* (2003). However, no investigation or discussion in the design reports quantified the existing surfing conditions. Thus, if the reefs were built, it would have been difficult to prove how the development impacted surfing. An independent review (Mead, Black, and Scarfe, 2004) found a failure to relate existing scientific surfing literature to the design or to demonstrate an understanding of coastal processes during the design process. Local concerns were poorly answered with a fact sheet with questions and answers that were unsupported by evidence, badly researched, and often incorrect with respect to existing knowledge of oceanography and surfing wave processes (Mead, Black, and Scarfe, 2004). Repeated statements that the reefs would not impact surfing amenities were made. Since the three 250-m long reefs' primary function was to break waves prior to them breaking on the beach, it was impossible that the reefs would not impact on the inshore surfing waves. Modeling simulations and reviews of existing literature demonstrated that waves breaking on the reef, as well as those passing over the reef, would be significantly modified, causing a significant change to the existing surfing conditions in the area.

The design of the proposed reefs can be seen in Figure 7. Mead, Black, and Scarfe (2004) found that the reefs would not break waves suitable for surfing. In addition, it was predicted that inshore surfing conditions would be negatively impacted due to wave focusing and wave-induced currents. The "wings" at each end of the reef were designed to mitigate effects of the reef, but Mead, Black, and Scarfe (2004) found that the design would impact surfing as it did not consider refraction, assess dominant wave directions and height, or draw from the abundant amount of available literature. The review report and public protest resulted in the last-minute abandonment of the project, demonstrating the importance of

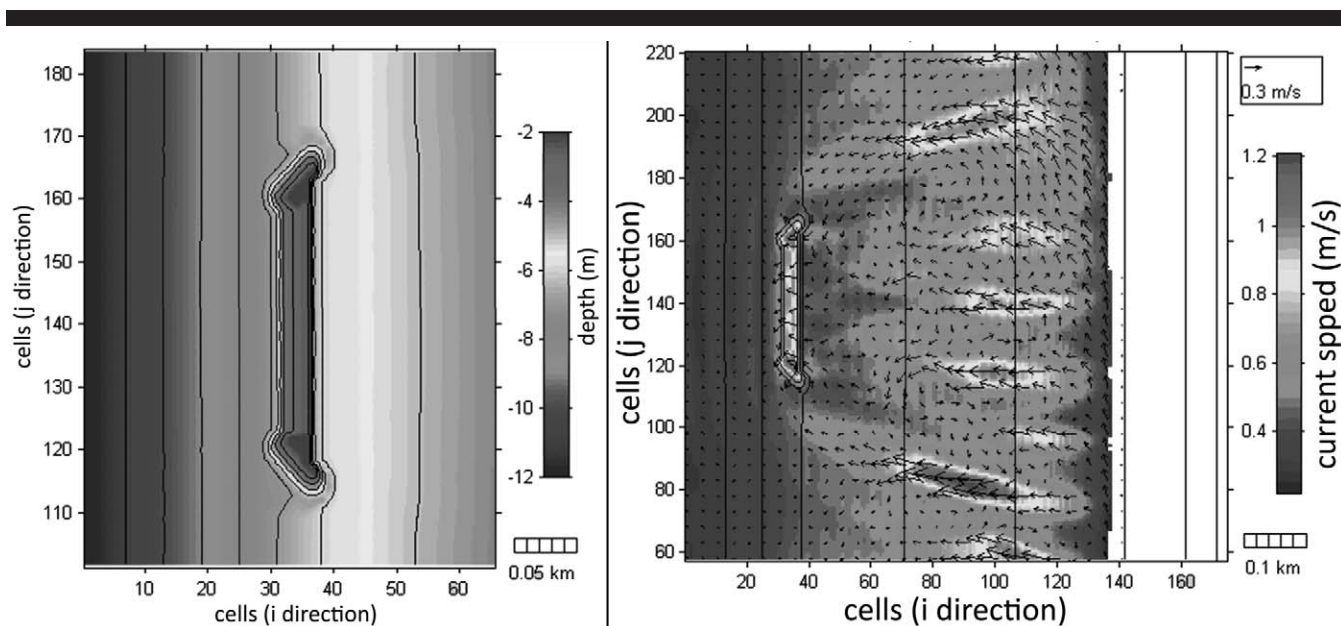

Figure 7. Model grids showing design of the coastal protection reefs (bathymetry, left) and predicted wave-induced currents (right) for a 1.2-m wave condition (Mead, Black, and Scarfe, 2004). For a color version of this figure, see page 666.

developers and consenting agencies seriously considering impacts on surfing amenities during coastal management. The Gold Coast City Council concluded that construction would not go ahead without the consent of the local stakeholders, including the surfing community.

Case Study 3: Mission Bay Jetties, San Diego (California)

Jetties are a common type of coastal engineering that can modify surfing wave quality (Buonaiuto and Kraus, 2003; Raichle, 1998; Scarfe *et al.*, 2003a, 2003b). In the case of Mission Bay (Figure 8), the northern jetty creates a consistent and high-quality surfing break that can have good waves even when surfing conditions on the adjacent beach to the north are often poor (Scarfe *et al.*, 2003b). The surfing waves immediately north of the jetty peel for a significantly longer time than farther north at Mission Beach, and they break with higher intensity. The surfing takeoff point is reasonably consistent, whereas the wave peak and breaking location vary significantly at the beach breaks. Surfers desire predictable, clean waves where the wave break point peels along the wave crest at a surfable but challenging speed, and jetties can aid in the formation of these types of waves. Although the Mission Bay jetties improve surfing quality, a proposal to further improve vessel navigability almost destroyed the surfing break (Pratte, 1987).

The orientation of a jetty to the dominant wave direction has a large impact on the surfing conditions (Scarfe *et al.*, 2003a), and this is evident at the Mission Bay jetties. The obtuse angle between the beach and the northern jetty catches waves. Waves compress against and reflect off the jetty

wall, causing focused wave energy. In comparison, the southern jetty is at an acute angle to the beach, creating different wave refraction, diffraction, shoaling, and other preconditioning wave processes. Thirty-six years of wave data collected by the Scripps' Coastal Data Information Program (Figure 9) shows the variety of wave directions the jetties are exposed to. The bidirectional spread is caused by differing winter and summer swell sources for Southern California and the effects of the offshore San Clemente Island.

The northern jetty has been categorized by Scarfe *et al.* (2003a) as a type 1 jetty (Figure 10). This type of surfing break has a long jetty wall, and surfing waves to peel along the buildup of sand (termed a "fillet") against the jetty. Type 4 jetty inlets, such as the one between the two jetties, do not have a significant ebb delta to modify wave energy. In this case, there may not be a significant delta because of the low rainfall and lack of sediment supply in California (Willis and Griggs, 2003).

Jetties require maintenance, and considering coastal sectors (such as surfing) outside the main project scope during the management of these jetties can help positively affect coastal users. In order for surfing to be included in jetty management, more research is required that builds on previous work on the topic (Buonaiuto and Kraus, 2003; Raichle, 1998; Scarfe *et al.*, 2003a, 2003b). The study of natural surfing breaks will also contribute to this goal, such as the filletlike sandbar and long natural jettylike structure of the Moturiki Island tombolo at Mount Maunganui (discussed later), which resembles an artificial break created by jetties. Thus, dissecting surfing breaks, such as at the Main Beach at Mount Maunganui, help us understand how to incorporate surfing into coastal engineering structures.



Figure 8. Aerial photograph of Mission Bay jetties, and location of the surfing break created by the northern jetty wall.

Case Study 4: Main Beach, Mount Maunganui (New Zealand)

The Main Beach at Mount Maunganui, New Zealand (Figure 11) is an example of a surfing break that is currently subject to artificial nourishment. The nourishment is placed immediately offshore of the beach (5–10 m depth) as a dredge despoil site that also offsets the loss of littoral sediment trapped in the dredged navigation channel of the Port of Tauranga (Spiers, 2005; Spiers and Healy, 2007). The effects of this nourishment to surfing amenities are unknown as information was not recorded on the surfing conditions before the nourishment began. The lack of serious surfer complaints at the Mount Maunganui beaches, all of which are affected in some way by dredging or nourishment, suggests that effects may have been minor. However, this illustrates the importance of collecting relevant baseline information on existing surfing breaks if future changes are to be properly assessed, including surfing breaks suitable more for novice and intermediate surfers, such as this location.

Moturiki Island connects to the beach with a tombolo and plays a critical role in the creation of the surfing break identified in Figure 11. A buildup of sediment against the island has been measured using multibeam echo soundings (Scarfe,

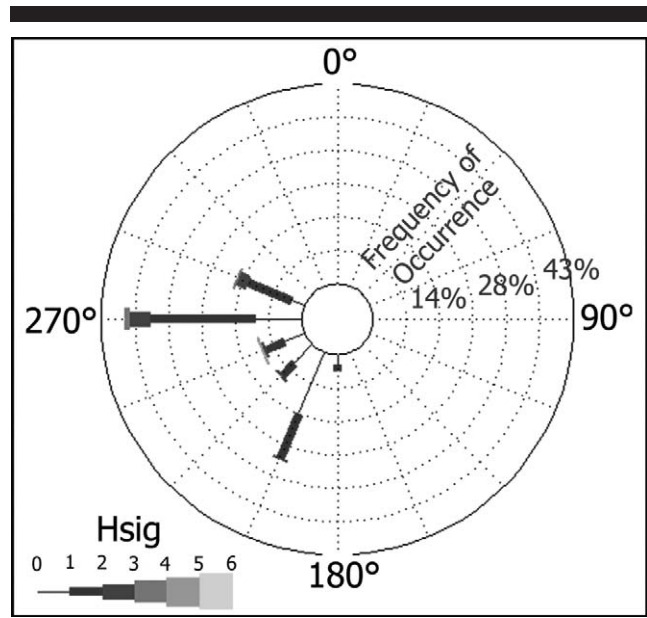

Figure 9. Directions and H_{sig} for waves in 198 m depth offshore of Mission Bay. (Wave rose from <http://www.cdip.ucsd.edu> using 1981–2007 measurements.)

2008), and this feature causes wave breaking with a low “breaking intensity,” suitable for beginner or longboard (Malibu) surfing. A study of wave conditions during storm and surfing events found that this surfing break is rideable more often during northerly wave events (Scarfe, 2008). The monochromatic wave model WBEND from the 3DD suite of models (Black, 1997, 2006; Black and Rosenberg, 1992) was used by Scarfe (2008) to predict wave refraction (Figure 12). The effect of the offshore islands on wave patterns at the Mount Maunganui beaches can be clearly seen. During the wave event shown, a band of high wave energy approaches the Main Beach from the north–northeast, creating suitably preconditioned waves for breaking on the sandbar against Moturiki Island.

Although it is unknown to what extent the surfing break has been modified, Dally and Osiecki (2007) and Benedet, Pierro, and Henriquez (2007) discuss how nourishment has the potential to improve, sustain, or destroy the quality of surfing waves. If the level of nourishment was increased or reduced significantly, the beach could evolve with unknown effects to surfing amenities. If “targeted nourishment” was used, it is possible that nourished sediment could be placed to precondition and break waves, further improving surf quality. Although using different terminology, the concept of targeted nourishment is discussed by Dally and Osiecki (2007). Their discussion involves placing fill directly into the surf zone to create a system of artificial shoals. However, Spiers (2005) shows how an offshore spoil mound modifies wave focusing, as does the Aramoana case study (see next section). Thus, “targeted nourishment” extends the Dally and Osiecki (2007) definition to include any nourishment that modifies the preconditioning or breaking of surfing waves. Nourishment could also be stabilized with geotextile sandbags to cre-

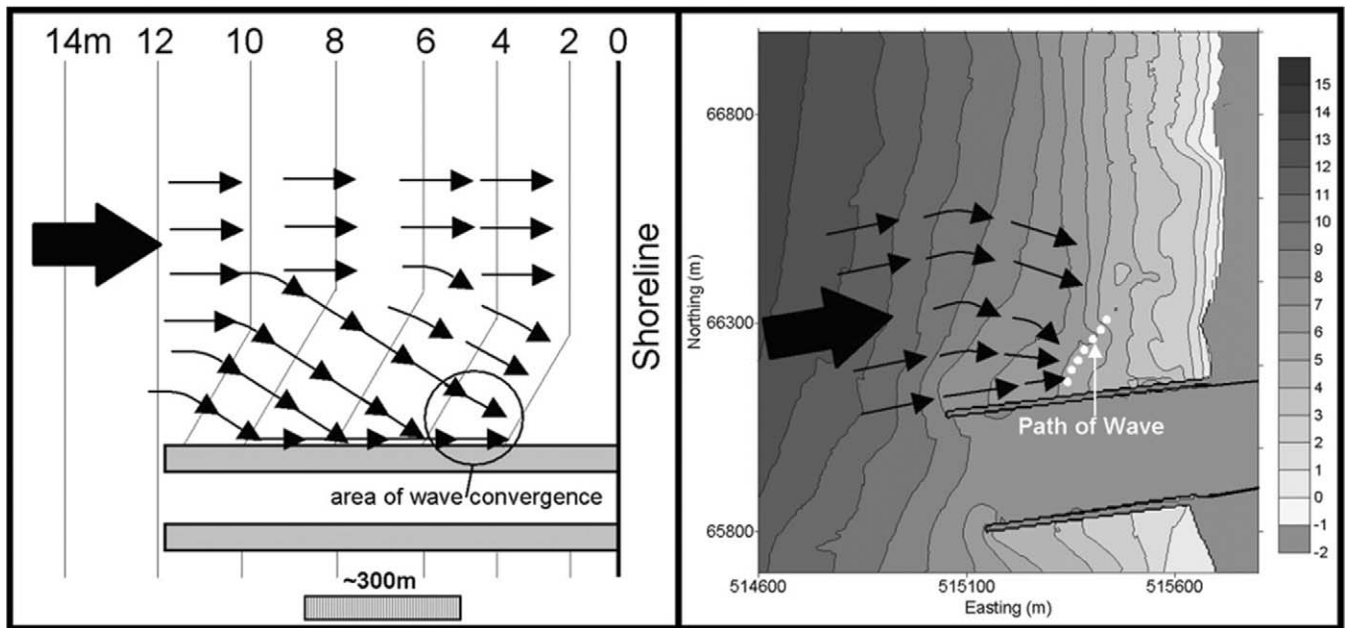

Figure 10. Mission Bay jetty categorized as a type 1 jetty, where a long jetty wall and delta-absent inlet cause surfing waves to peel along the sand fillet against the jetty (Scarfe *et al.*, 2003a).

ate sedimentary and reef features suitable for surfing, such as in the “multipurpose sediment controlling structures” discussed by Scarfe (2008). Such geotextile containers have been installed by Mead, Black, and Moores, (2007) and shown to modify inshore surfing bar formation by Black and Mead (2007) and Scarfe (2008). The interactions between beaches and surfing, or nourishment and surfing, have not been heavily researched (Scarfe, Healy, and Rennie, 2009); thus, the concept of targeted nourishment is still experimental. The work of Benedet, Pierro, and Henriquez (2007); Black and Mead (2007); and Scarfe (2008) on the use of the Wright and Short (1984) beach-state models and surfing needs to be extended for successful design of targeted nourishment.

Case Study 5: Aramoana Beach, Dunedin (New Zealand)

An example of artificial nourishment, combined with a large engineering structure around a surfing break, is found at Aramoana Beach, Dunedin, New Zealand (Figures 13 and 14). The surfing break is adjacent to a 1350-m-long jetty that stabilizes the Otago Harbor entrance. The surfing break is no longer natural but still possesses important surfing amenities. The tidal harbor is 4600 ha (calculated using ArcGIS version 9.2), creating a large ebb delta. The navigation channel is dredged for the Port of Otago, and one of the spoil grounds is immediately offshore of the Aramoana surfing break. Currently, the shoal rises to around 6 m below the surface. A hydrographic survey from Kilpatrick (2005) and the refraction modeling undertaken here are used to show that surfing waves form due to extreme wave focusing and

that the spoil ground is likely to have improved surfing conditions at the surfing break.

The area inshore of the spoil ground is an extremely good surfing break that can only be surfed during northerly swells, which are less frequent than southerly swells. The combination of the delta, the spoil ground, and the equilibrium the beach has formed with the jetty help create extremely good waves that break on a beach. The survey of the surf zone by Kilpatrick (2005) showed almost no features to cause wave breaking; therefore, surfing waves are created almost completely by offshore preconditioning over the offshore features. Over time, as the entrance continues to be dredged and spoil is deposited offshore the surfing break, it is possible that the character of the surfing waves could change. So although the engineering activities are likely to have improved surfing conditions, the impacts of continued dredging and nourishment of the beach are unknown.

Kilpatrick (2005) compiled existing survey data from the Port of Otago and undertook a hydrographic survey of the surf zone using waterlevel corrections measured using real-time kinematic global positioning system water-level corrections (Scarfe, 2002b) to identify the main components of the surfing break. Five good surfing swell events were photographed, including positioning the surfing break with aerial photography from a helicopter. Modeling undertaken here with the MIKE 21 nearshore wind-wave model is used to show how the identified components transform waves during the surfing events. MIKE 21 is a nearshore wind-wave model that describes the propagations, growth, and decay of nearshore waves (DHI Software Staff, 2003). Since the Otago region is almost devoid of wave data, hindcast information from

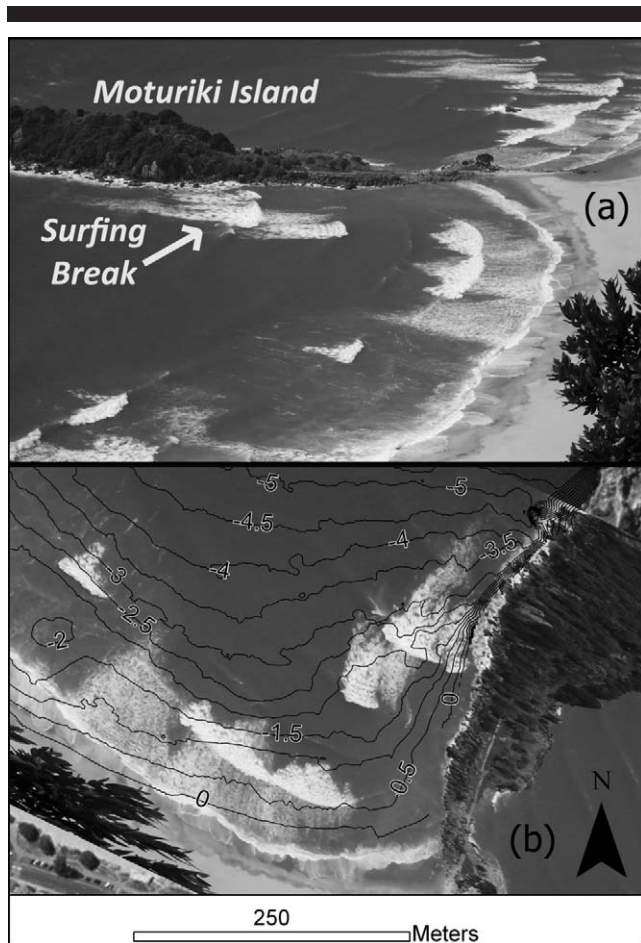

Figure 11. Oblique image of wave event at 1215 NZST, 5 October 2004, creating good beginner or longboard surfing waves. (a) Oblique image of breaking waves. (b) Rectified image overlaid on contours from a multi-beam survey of the beach. Wave conditions were 2.36 m (H_{sig}), 7.7 s (significant wave period, or T_{sig}), 10° mean direction with a tide level of 0.69 m (mean sea level). A good alignment between the breaking waves and a sandbar can be seen. Note that waves were focusing on the edges of the beach rather than in the center of the beach due to the offshore focusing patterns.

Gorman (2005) was used to drive the model boundary. Hence, no calibration data was available for the model. The results still showed the general refraction patterns and magnitude of focusing. More research is required to investigate the nuances of the surfing break and to validate the model's accuracy. However, five surfing swell events have been modeled by Scarfe (2008; see also Kilpatrick, 2005), and the premier surfing condition (event 2; Figure 15) from 19 June 2005 is presented here. This is a large surfing event with offshore winds producing clean, surfable waves that were variable in size (Kilpatrick, 2005).

Kilpatrick (2005) was able to compile a bathymetry dataset around the spoil ground from 1980 before the spoil mound was created. Thus, a direct comparison of wave transformations with and without the spoil ground has been undertaken. The modeling results (Figures 16a and 16b) show convergent

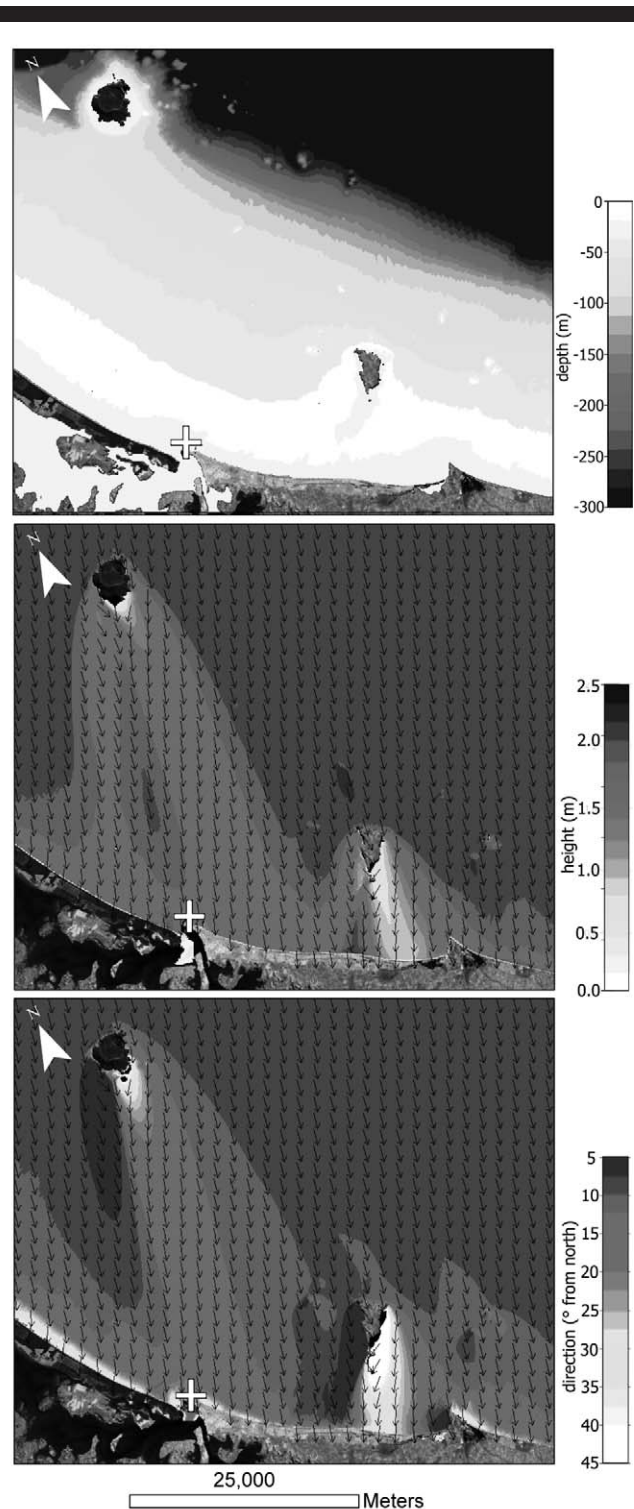

Figure 12. Offshore depth, wave height, and angle predictions for surfing waves in Figure 11. Note the effect of the offshore islands and band of higher wave energy directed at the Main Beach (marked by cross). For a color version of this figure, see page 667.

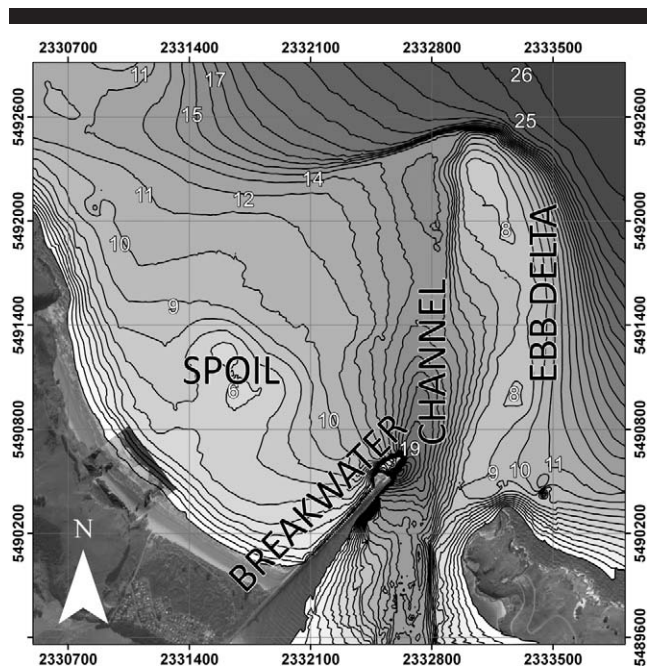

Figure 13. Macroscale bathymetry and features around the Aramoana surfing break. The position of the surfing break is highlighted by the small aerial photograph taken by Kilpatrick (2005), to the southeast of the spoil mound.

focusing of waves over the ebb tidal delta, creating a prominent band of focused wave energy that varies somewhat in focusing location along the beach depending on wave direction. An oblique photograph from the helicopter flight by Kilpatrick (2005) was rectified, allowing precise positioning of the exact surfing area relative to the contours and model output. The main surfing area is between -1.5 m and -3.5 m relative to chart datum (\sim lowest astronomical tide [LAT]), and although this will not always be the largest area of wave focusing, it is a popular surfing location. The location of wave focusing from 19 June 2005 is aligned perfectly with the main surfing location. The location and degree of the focusing will change between sets of waves, but Figures 16a and 16b should still represent the mean focusing patterns well.

The wave transformations improve the surfing through two process: (i) wave focusing creates a gradient in height along the wave crest, promoting wave peeling as the region of larger wave height breaks farther offshore before the sections with smaller wave heights (Battalio, 1994; Beamsley and Black, 2003; Mead *et al.*, 2003; Scarfe, Healy, and Rennie, 2009), and (ii) the spoil ground slightly rotates the waves, causing less of an angle between the wave orthogonal and the surf zone contours. Table 2 shows focused wave heights for each simulation at the main surfing area. Wave focusing is not as apparent at the main surfing area in surfing swell events 4 and 5 (Kilpatrick, 2005), as the spoil mounds focus the wave farther northwest along the beach due to the southeasterly origin of the swells. The gradient in the wave crest can be seen in Figure 15. Table 3 shows waves are approaching less perpendicular to the surf zone contours when the

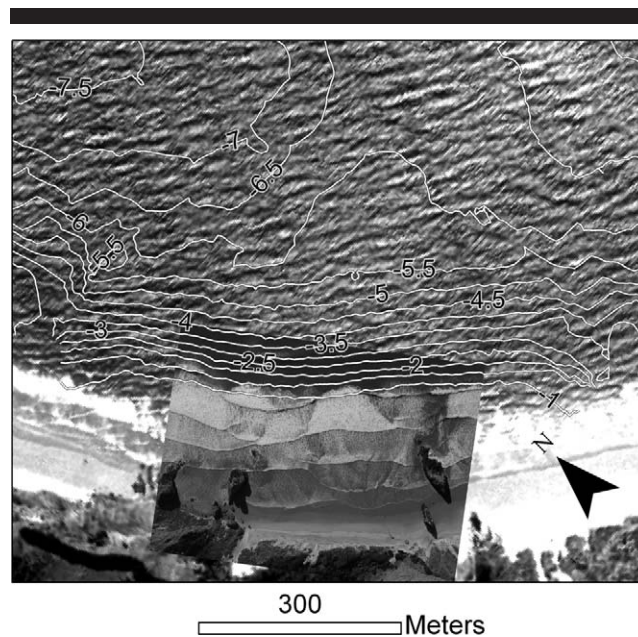

Figure 14. Mesoscale bathymetry and features around the Aramoana surfing break surf zone. The position of the surfing break is highlighted by the small aerial photograph taken by Kilpatrick (2005), and the spoil ground is immediately offshore of the image.

spoil mound is present. This does not relate to an increase in peel angle of exactly the same size, but it will generally increase peel angles, improving surfability.

Case Study 6: The “Whangamata Bar,” Whangamata (New Zealand)

Whangamata is located on the Coromandel Peninsula (New Zealand), and the coastal development history of the area,



Figure 15. Photograph of surfing event 2 from Kilpatrick (2005). The surfing wave occurred at 1606 NZST (19 June 2005), and the photo is an example of extremely good surfing waves breaking on a beach break from offshore focusing. The conditions on the day were as follows: tide = 1.76 m (chart datum), direction = 80° , $H_{sig} = 1.70$ m, period = 12.3 s, winds = offshore. For a color version of this figure, see page 668.

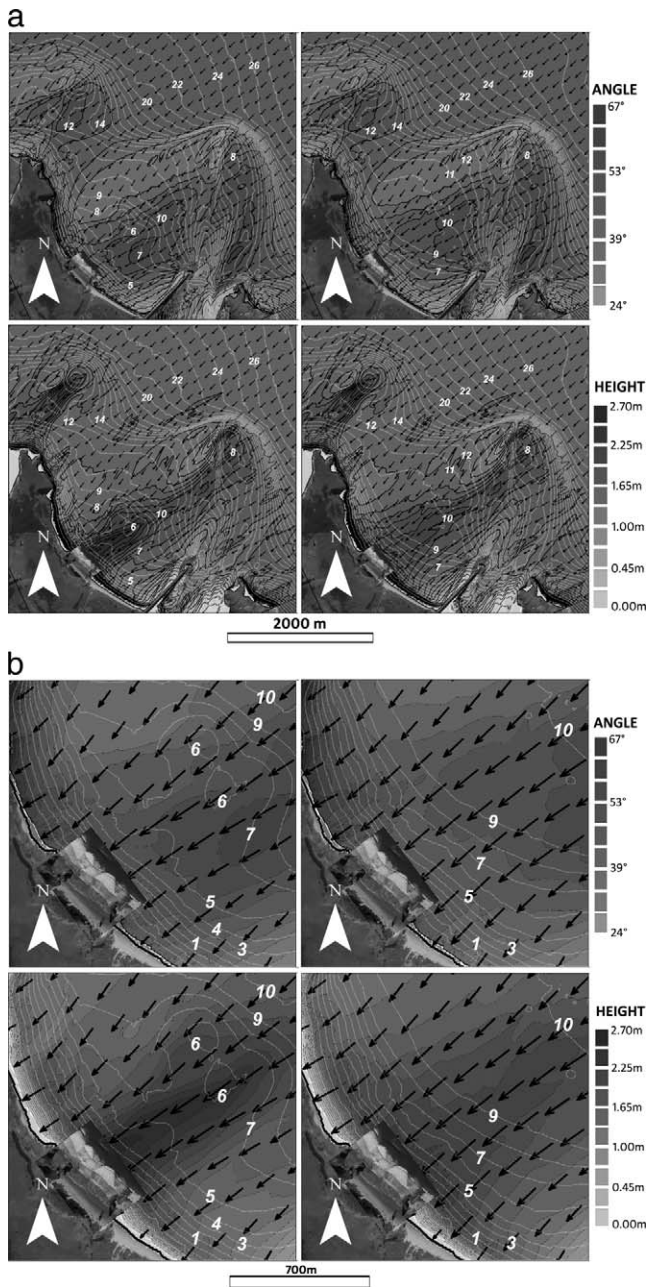

Figure 16. (a) MIKE 21 nearshore wind-wave model predictions showing extreme wave focusing over Otago Harbor ebb tidal delta, which is enhanced by the spoil ground just offshore of the surfing break (left with spoil mound, right without spoil mound). Model boundary conditions: tide = 1.76 m (chart datum), direction = 80°, $H_{sig} = 1.7$ m, period = 12.3 s. (b) MIKE 21 nearshore wind-wave model predictions showing extreme wave focusing over Otago Harbor ebb tidal delta, which is enhanced by the spoil ground just offshore of the surfing break (left with spoil mound, right without spoil mound). Model boundary conditions: tide = 1.76 m (chart datum), direction = 80°, $H_{sig} = 1.7$ m, period = 12.3 s.

Table 2. The degree of wave focusing with and without the spoil ground directly offshore the main Aramoana surfing area.

		Wave Height (m)	Increase in Wave Height
Event 1	With spoil ground	3.27	7.2%
	Without spoil ground	3.05	
Event 2	With spoil ground	2.72	22.5%
	Without spoil ground	2.22	
Event 3	With spoil ground	3.44	7.2%
	Without spoil ground	3.21	
Event 4	With spoil ground	2.13	3.4%
	Without spoil ground	2.06	
Event 5	With spoil ground	1.93	-0.5%
	Without spoil ground	1.94	

along with human interactions with the natural environment, is covered in Quinn (2007). The beaches (Figure 17) are popular for surfing, and the “Whangamata Bar” is one of the best surfing breaks in the region. Quinn (2007) discusses the iconic nature of the surfing break to surfers, and the opinions of opposing parties on the marina development have been captured in a four-part radio documentary by Auckland, New Zealand, radio station 95BFM. Unfortunately, the consenting agency or the developer is not included in the documentary to provide a completely balanced discussion.

Whangamata Bar differs from the beach surfing locations at Whangamata Beach because waves break on an ebb tidal delta (Figure 18). The delta transforms ordinary waves into surfing waves through a series of processes, including wave focusing (Beamsley and Black, 2003; Mead *et al.*, 2003), wave rotation (Black and Mead, 2001), and wave breaking (Mead and Black, 2001c; Vaughan, 2005). Depending on the oceanographic conditions, the takeoff area and path of the surfing wave will vary. More information on the behavior is included in Vaughan (2005).

The harbor is one of many rapidly infilling estuaries in the area. Hot Water Beach and Opoutere are two nearby estuaries that are completely filled (Sheffield, Healy, and McGlone, 1995). The surrounding catchment is 56 km², with ridges up to 690 m high and steep valley slopes that are easily eroded (Sheffield, Healy, and McGlone, 1995). Much of the catchment has been cleared, accelerating the natural rate of infilling of the estuary (Sheffield, 1991). Understanding infilling rates is important for sustainably managing the surfing amenities relating to the delta.

The harbor inlet has been categorized by Hume and Henderdorf (1993) as a type 4, single-spit, barrier-enclosed es-

Table 3. Effect of the spoil ground on wave directions at the Aramoana surfing break.

	Wave Direction with Spoil Ground (°)	Wave Direction without Spoil Ground (°)	Difference (°)
Event 1	50	43	7
Event 2	53	47	6
Event 3	54	51	3
Event 4	65	62	3
Event 5	67	64	3



Figure 17. Location of the Whangamata Bar surfing break, proposed marina, offshore focusing reef (shoals at 6.5 m from 12 m deep), and harbor inlet. (Background map stream over the Internet from ArcIMS geographic data server of Land Information New Zealand.)

tuary created through fluvial erosion. The characteristics of this type of inlet generally include small freshwater inputs and spits that are formed based on the littoral drift characteristics of the coast, with limited exchange of water between the estuary and the sea (Hume and Herdendorf, 1993). The shape and location of the ebb delta move in a dynamic equilibrium based on wave, wind, current, and sedimentary forces. More specifically, this equilibrium is controlled by tides, infragravity wave energy, wind-driven circulation, fluctuations in sediment supply, river inputs, and wave-induced processes. This equilibrium will be affected as processes such as sediment infilling and potential climate change and sea level rise occur. Exchanges of sediment between the ebb and the flood deltas are likely to occur, influencing the ebb delta morphology and, consequently, surfing amenities.

The rock headland, Te Karaka Point (Figure 17), stabilizes the channel and sandbar, which is a factor in the consistency of the delta location and surfing wave shape. From a surfing amenity and coastal management perspective, the delta is delicate and can potentially be affected by changes in the estuary and the catchment, including the cumulative impacts of multiple activities. For instance, a causeway construction in 1976 modified the natural harbor character and is blamed for the growth of mangrove habitat in the area (Quinn, 2007). Thus, establishing the cause-effect relationships among different activities is difficult. A simple method employed here shows the migration of the ebb delta over time but does not link the observed changes to any cause.

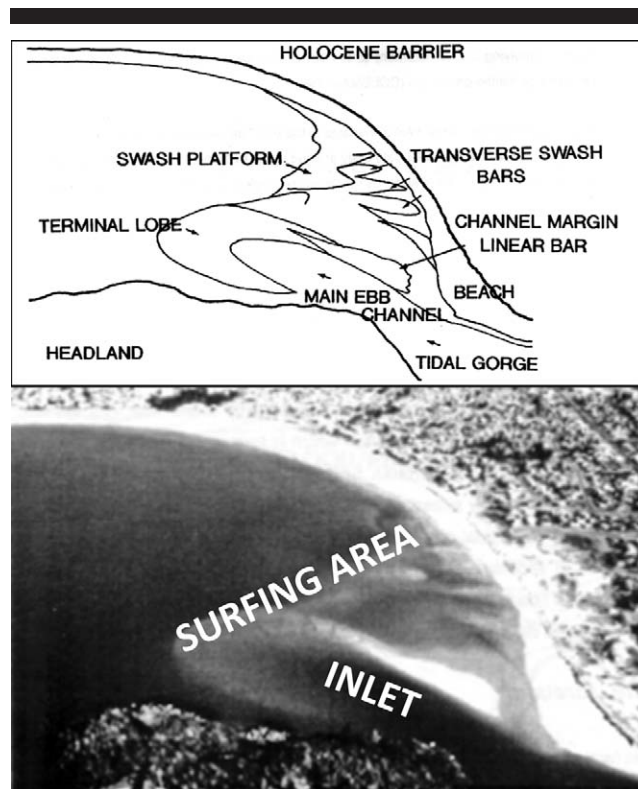

Figure 18. Morphological features of the ebb delta (top) and main surfing area and navigation channel (bottom; adapted from Sheffield, 1991). The navigation channel area is used by surfers to access the surfing break and by boats entering and leaving the harbor.

Analysis of four georeferenced aerial photographs between 1944 and 2002 shows that the delta's channel margin linear bar has moved away from the headland (Table 4). The shoreward tip of the bar was essentially parallel with the headland between 1973 and 2002 but was at an angle to the headland in 1944. The available aerial photographs show that the bar's crest has moved approximately 70 m away from the headland between 1944 and 2002. The reasons for the movement have not been investigated here but could include construction of a causeway, sedimentary inputs from land use change, swell effects, and possible spring-neap or longer-term tidal variations.

The Whangamata harbor is an important mooring location for recreational boats; hence, the inlet and ebb delta are a

Table 4. Changes in the distance of the channel margin linear bar from the rock headland, Te Karaka Point.*†

Year	Shoreward Tip (m)	Offshore Tip (m)	Average (m)
1944	125	185	155
1973	197	226	212
1993	197	187	192
2002	217	224	221

* Measurements made from shoreward and offshore end of visual bar.

† Distances calculated using GIS measurements from historical aerial photographs.



Figure 19. Coastal space conflict between surfers and boats when a February 2007 recreational fishing competition coincided with a good surfing swell. (Photo from John Wilson.) For a color version of this figure, see page 668.

mixed user coastal space (Mather and Rennie, 1997). Conflict between local surfers and boat users has been evident in recent years as the different groups share a coastal resource. This conflict (summarized in Quinn, 2007) was highlighted when a fishing competition between 8 and 10 February 2007 coincided with good surfing conditions on the 8 and 9 February. The fishing contest involved 142 boats, and the inlet channel was being used concurrently by both surfers and fishermen (Kiwī Surf Staff, 2007, p. 22). Surfers were riding waves peeling to the south (toward the beach) and north (toward the inlet channel). The space conflict is highlighted by a recreational fishing vessel passing through the surfing break in Figure 19.

Problems with existing boating facilities led to the planning of a marina development in 1992. It was argued that the marina would alleviate problems associated with the current moorings in the main channel of the harbor by providing a safe, all-tide alternative for boats (Whangamata Marina Society Staff, 1995). Surfers and local Maori (the indigenous people) have vigorously, but unsuccessfully, opposed the development throughout the statutory permitting process (Christensen and Baker, 2007; Kapua, 2007). Opposition from the surfing community was because of the importance

of the harbor hydrodynamics, sediment transport pathways, and delta system to the surfing on Whangamata Bar.

In a near-final decision, the minister of conservation halted the project due to the various potential negative environmental effects. Subsequently, an unprecedented decision in New Zealand environmental law was made and the Court of Appeal overturned the minister of conservation's decision to decline the application on procedural grounds. Consequently, under extreme political pressure, the minister for the environment (acting under an also unprecedented delegation from the minister of conservation) approved the development. The marina's resource consent is now being exercised and enables the reclamation of wetlands and the dredging of 167,000 m³ of sediment, plus 6000 m³ of annual maintenance dredging (Quinn, 2007).

To date, there has not been a detailed assessment of the individual or cumulative effects on surfing of any of the various coastal engineering activities and other land use changes that are affecting the hydrodynamics and sediment morphology of the harbor and, hence, the ebb delta. A lack of strategic planning of surfing resources in the area contributes to the defensiveness of the surfing community to development of the harbor.

Although it is beyond the scope of this study to assess the actual impacts of the marina development on surfing, three activities that could affect an ebb delta surfing break like Whangamata Bar when developing a marina in an estuary have been identified:

- (i) Construction of the marina and dredging of the harbor navigation channels
- (ii) Dredging of the ebb delta
- (iii) Dumping of nourishment offshore or near the Whangamata beaches

Marina construction and harbor dredging could change the tidal prism, modifying the ebb and flood delta character. This issue has been addressed by the New Zealand courts, and impacts were not considered significant due to the small change in tidal prism and remote location of the dredging. However, the minister for the environment added a condition to monitor the impacts of the marina development on the ebb delta, highlighting this mechanism as important to consider for such activities in the vicinity of surfing breaks. The effects of dredging might be adverse for a different type of development or at another surfing location. The second activity that could potentially impact the marina is the possible requirement for future dredging to maintain navigable channels, including dredging the channels, inlet, and delta. Considering that the estuary is infilling, this second activity needs to be managed in a strategic manner that considers the oceanographic impacts to the surfing break. This is especially true if the surfing break is directly dredged for navigation. The third activity that could occur is the dumping of dredged sediment in a manner that changes the surfing waves. This could be placing dredged material on the neighboring beach, offshore of Whangamata, or on the delta. Although from a coastal erosion point of view nourishing a beach makes sense, placing sediment where it is likely to reach the surf zone could potentially alter the shape of the

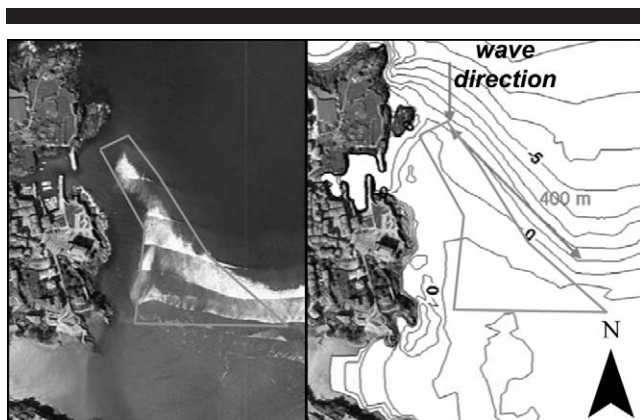

Figure 20. Aerial photography and survey of the Mundaka surfing break, and an ebb tidal delta's channel margin linear bar (adapted from Cearreta *et al.*, 2005). The polygon area represents the channel margin linear bar, or wedge crest of the surfing break.

delta and, hence, the surfing break components. This was shown to occur in a positive manner at Aramoana, but the activity could have negative impacts.

Now that the marina is likely to proceed, monitoring of any impacts to the ebb delta is the next concern for surfers. This includes the cumulative effects of multiple coastal activities that can impact surfing amenities. A surf monitoring study of this type needs to have three aspects:

- (i) Developing a baseline understanding of surfing wave character, the skill level of surfers able to use the break during different conditions, oceanographic processes around the surfing break, important bathymetric features, and sedimentary patterns
- (ii) Monitoring changes to the character of surfing waves over time, including surfing parameters discussed in Scarfe, Healy, and Rennie (2009), and changes in the skill level of surfers able to surf the waves
- (iii) Monitoring changes to the wave, current, and sedimentary patterns that control the shape, size, and location of the delta over time and hence dictate surfing conditions.

An oceanographic study around similar surfing break to the Whangamata Bar has been undertaken in Mundaka, Spain (Figure 20; Cearreta *et al.*, 2005), and this study is of high relevance when designing a monitoring program. The Mundaka surfing break's main wave breaking component is the channel margin linear bar of the ebb delta surfing break, or the crest of the wedge surfing component, and this is similar to Whangamata Bar. The inlet channel and channel margin linear bar are stabilized by a rock headland, further showing the similarities between the two locations, although there is a noticeable difference in the scale of the wedge crest (Whangamata is 130–200 m; Mundaka is 400 m), as well as the contributions of river sediments. Cearreta *et al.* (2005) collected and analyzed numerous types of the environmental information of importance to a surfing break monitoring program, especially at Whangamata, including the following: ae-

rial photography, wave refraction, hydrographic soundings, wave climate, wind climate, sediment grain size analysis, suspended sediments, tides, *in situ* currents measurements, and Acoustic Doppler current profiler measurements.

ICZM AND SURFING BREAK PROTECTION

The preceding case studies have shown that surfing breaks can be altered, created, or destroyed by coastal engineering. The unplanned effects on surfing breaks illustrate the need to proactively protect surfing breaks and to embrace opportunities to enhance them where appropriate. The case studies have also illustrated that not all engineering effects result in bad surfing outcomes. In fact, George (2004), in a discussion of artificial surfing breaks, listed more than 60 coastal engineering projects in the United States that inadvertently improved the quality of surfing waves or indeed created a surfing break where one did not previously exist. It is likely that with a few engineering design modifications many more coastal engineering projects could have improved surfing amenities.

The United Nations (1992), through Chapter 17 of Agenda 21, has advocated an inclusive, integrated approach to the management of multiuser coastal zones. Integrated coastal zone management¹ is widely seen as an approach to achieving this. Essentially, ICZM practices are adopted to “establish and maintain the best use and sustainable levels of development and activity use in the coastal zone, and, over a period of time, improve the physical status of the coastal environment in accordance with certain commonly held and agreed norms” (Healy and Wang, 2004, p. 231).

Modern ICZM practices (Cicin-Sain, 1993; Healy and Wang, 2004; Jacobson and Rennie, 1991; Rennie, 2000 and 2003; Wood, 2003) integrate the coastal space requirements of various coastal user groups and can benefit recreational surfing. One of the most important aspects of ICZM is that it is forward looking and aims to preserve resources for future generations (Healy and Wang, 2004). The definition of “resources” is extended here to include the natural features and processes that create surfing waves. An example of a project attempting to integrate multiple benefits is discussed in Healy *et al.* (2002). The project's main objective was to redesign a coastal port, although the project included amenity values as an ancillary redesign consideration. Surfing enhancement was considered but has yet to be given any detailed design consideration, and economic factors have placed the development on hold.

The reactive participation of surfers during the planning of proposed coastal engineering activities at Palm Beach and Whangamata has been significant. Although strategic consultation with surfers was not necessarily undertaken by consenting authorities, the impact of lobbying from surfers on the final outcome has been noticeable. The case studies indicate the importance of an integrated approach. However, specific discussions of ICZM and surfing are not apparent in the peer-reviewed literature examined as part of this project

¹ ICZM is also termed integrated coastal area management (ICAM) or integrated coastal management (ICM).

(Scarfe, Healy, and Rennie, 2009). Problems that have been identified by Healy and Wang (2004) in the absence of ICZM, such as unnecessarily reactive management, cumulative impacts, and fragmented geographic planning, are noticeable in the presented case studies.

The EIAs, assessments of environmental effects, and environmental impact reports are anticipatory, participatory, integrative environmental management tools that provide decision makers with an indication of the potential consequences of development (Wood, 2003). It is essential that EIAs be based on the now-significant volume of science on surfing research (Scarfe, Healy, and Rennie, 2009). There are more than 100 EIA systems worldwide, and although they differ in detail, the basic principles are similar (Wood, 2003). They are usually required by law as part of the environmental permitting for an activity and are a tangible step in the ICZM process. They involve an investigation into the effects of an activity on the environment and are a central tenet of ICZM (Healy and Wang, 2004). All potential effects, to all sectors of the environment, need to be considered in detail so that the impacts can be avoided, remedied, or mitigated. Investigating impacts to biophysical bottom lines during EIA is a mechanism to protect surfing amenities. An EIA should consider any sheltering, focusing, or rotation of wave energy offshore of the surfing break. This offshore region is termed a "swell corridor," and waves travel and transform through the corridor on the way to a surfing break and are affected by reefs, islands, and bathymetric features.

At a higher planning level, a strategic environmental assessment (SEA) is a form of EIA that assesses the impacts of the policies and rules in plans, the effect of plans, and the effect of programs of work that might involve several individual projects (Wood, 2003). An SEA can result in the setting of parameters for EIAs of projects and can determine the nature of activities in an area. Consideration of surfing resources and amenities in an SEA provides opportunities to ensure that surfing-specific baseline data collection is incorporated into project and program preparation, the prevention or avoidance of activities that adversely affect surfing breaks, and the inclusion of surfing and its enhancement as a consideration in EIAs. For the purposes of this paper, reference to EIA encompasses both the specific project EIAs and the broader SEA process unless specifically separated.

In the New Zealand context, for instance, an EIA is undertaken for any activity to ensure that it meets the provisions of the relevant Resource Management Act plans and policies. The provisions of the plans are set through a SEA process but have not traditionally placed much attention on surfing. However, in New Zealand, central government has included the protection of surfing break in its draft 2008 coastal statement. Over time, this statement will guide the management at a regional level through plans and policies—to the benefit of surfers. Unfortunately, the statement only identifies very few surfing breaks, and submissions are being made to amend this statement to include many more surfing locations. The statement is as follows:

Policy 20 Surf breaks of national significance:

The surf breaks at Ahipara, Northland; Raglan, Waikato;

Stent Road, Taranaki, White Rock, Wairarapa; Mangaunu, Kaikoura; and Papatowai, Southland, which are of national significance for surfing, shall be protected from inappropriate use and development, including by:

- (a) ensuring that activities in the coastal marine area do not adversely affect the surf breaks; and
- (b) avoiding, remedying or mitigating adverse effects of other activities on access to, and use and enjoyment of the surf breaks (Department of Conservation Staff, 2008).

Although the impacts of an activity on environmental assets such as biodiversity are often included in EIAs, impacts on surfing breaks have traditionally been ignored. For example, at the time of constructing the Manu Bay boat ramp, all environmental permits were obtained and the boat ramp was built legally. Although EIAs were beginning to be used 30 years ago (Wood, 2003), a serious investigation of impacts of the boat ramp on surfing waves was not undertaken because EIA techniques for surfing breaks did not exist and were not required during the permitting process. Where impacts to surfing have been acknowledged, they are usually only reviewed superficially. Statements such as "there will be no negative effects to surfing wave quality" are made without scientific rationale (Mead, Black, and Scarfe, 2004).

An excellent example of a poor EIA on surfing conditions was that undertaken for Chevron's El Segundo (California) coastal oil refinery (Nelsen and Howd, 1996). The oil refinery was at threat from erosion, and Chevron sought permits for construction of a groin to retain sediment. Local surfers required use of the same coastal space. Several experts on coastal processes predicted no negative impacts to surfing, with the possibility of an improvement to surfing conditions (Nelsen and Howd, 1996). Surfrider Foundation, acting on behalf of local surfers, raised concerns with the groin construction in spite of the experts' assessment. This resulted in the Californian Coastal Commission permitting the development but with a unique condition that if the initial EIA was incorrect and there were adverse impacts on surfing conditions, funds had to be provided by Chevron to mitigate with an artificial surfing reef (Nelsen and Howd, 1996). Unfortunately for the surfers, the El Segundo reef never significantly improved surfing conditions (Borrero and Nelsen, 2003; Mack, 2003) because of the construction budget and limited existing knowledge of surfing wave transformations and reef construction techniques. A detailed EIA with alternative design considerations that address the various coastal users biophysical bottom lines could have resulted in a better outcome for surfers and the industry associated with the surfing break.

EIA Checklist and Overlay Techniques

The methods employed in the EIA process should be designed with two main criteria in mind: adding rigor to the process, and effectively communicating the nature of the effects (Morgan, 1998). Four basic methods have been developed over the years as aids to EIA: checklists, overlays, matrices, and networks. Each of these has advantages and disadvantages, and each has evolved and become more techni-

Table 5. Coastal activities and constructions that can have an impact on surfing conditions.

Artificial Nourishment	Port Developments	Jetty Construction or Extensions	Outfall Pipelines
Breakwaters	Piers	Boat ramps	Marinas
Seawalls	Dredging	Dumping of dredge spoil	Groins

cally and technologically sophisticated. The generic checklist is of interest here because it can be designed for a particular type of project (e.g., new artificial surfing reefs) or for types of environment (e.g., reef versus sand surfing breaks). Checklists provide a simple method for impact identification and ensuring that important effects are not overlooked. These may be general (able to cover any project and environmental type), generic, or specific (a “one-off” checklist designed for a particular project or setting; Lee, 1989; Morgan, 1998). Overlays are also particularly relevant as they address spatial characteristics not easily captured in other methods (McHarg, 1969). Now overlays are largely expressed through use of geographic information systems (GISs) and are an effective way to understand and communicate complex processes around surfing breaks. Matrices tend to be sophisticated versions of checklists in tabular format that make transparent the cause–effect assumptions of linkages between specific actions undertaken during a project and their assumed effects. They also underpin multicriteria evaluations. Networks can show cause–effect relationships diagrammatically and provide the basis for systems modeling.

Among the keys to effective use of any of these methods in ICZM is the identification and collection of relevant data (Frihy, 2001; Tiwi, 2004). Our research suggests a generic checklist of the information required for EIAs relevant to coastal activities near surfing breaks could easily be used in conjunction with GIS overlay methods to manage threats to surfing amenities. The discussion in this paper is limited to parameters relevant to checklists and overlays.

The EIA method of a checklist can be used to identify types of information that should be included in a surfing EIA. Table 5 shows the main coastal activities and structures observed on the coastline that can alter wave quality, and this can be used to decide whether a checklist of effects of such activities on surfing needs to be undertaken. The various surfing and oceanographic factors that should be considered when one of these developments occurs near a surfing break, and for use in a checklist, are shown in Table 6. An example of the environmental data types that could be used in a checklist when evaluating impacts to surfing are shown in Table 7.

Table 6. Surfing and oceanographic factors that can be used when undertaking a surfing EIA.

Bathymetry	Sediment Transport Pathways	Wave Refraction/ Diffraction/Shoaling	Breaker Intensity
Wave climate (inshore and offshore)	Sediment grain sizes within littoral cell	Peel angles	Breaking wave height ratio
Surfer numbers and seasonal variations	Precise location of surfing rides	Tidal patterns and long-term water-level trends	Surfable days <i>per</i> year
Wind patterns	Surfer skill level	Storm surge	Wave- and tide-induced current patterns

Additional considerations for the design of checklists will exist, but the presented tables still provide a starting point for coastal managers. Information obtained for such parameters can be published and built into coastal plans and SEA practices, as well as GISs and other database systems. It is important to recognize that while some spatial data can be readily collected at short notice, data on people’s use of areas may be much less readily available. Well-prepared surfing interest groups should invest in ongoing collection of such data so that it is readily available in case their surfing breaks are threatened (e.g., Nelsen and Rauscher, 2002). Techniques for gathering such information are available, although still somewhat experimental (e.g., Klein *et al.*, 2003; Polette and Raucci, 2003; Thomson, 2003).

Geographic information systems have made giant technological leaps forward in recent years and are being promoted as a key tool for ICZM (Bartlett and Smith, 2005; Wheeler and Peterson, 2007), with specific reference to the need for appropriate spatial data infrastructure (Longhorn, 2005). Development of geoprocessing techniques and models, 2D and 3D visualization, geodatabasing, and data communication over the Internet, as well as integration with modern computing strategies, enables powerful analysis and communication of spatial data. The point-and-click nature of a lot of modern GISs makes these systems available to a range of users. Many users, such as people viewing Internet-based street maps, may not even realize they are using GISs. The greater ability to analyze and visualize the environment around surfing breaks using GISs adds transparency and can aid in the protection and enhancement of surfing breaks, especially during the EIA and monitoring process.

The use of overlay techniques for studying surfing breaks has been undertaken since the first scientific study by Walker and Palmer (1971). Overlay techniques therefore have application to surfing studies beyond EIA requirements. The application of a coastal-specific GIS is covered in Breman (2002), and a marine-specific geodatabase schema is presented in Wright, Blongewicz, and Halpin (2007). The marine geodatabase schema allows exchange of common marine datasets among different GIS users and is important to consider when designing a surfing GIS in the ArcGIS (Environmental Systems Research Institute Staff, 2006) software environment. Various industries and environmental issues are explored in Breman (2002), including a surfing-specific GIS developed by Nelsen and Rauscher (2002) for the environmental surfing organization Surfrider Foundation, which stores and distributes information about the location and access to surfing breaks, as well as land-use patterns, pollution sources, beach erosion information, marine habitats, and wave char-

Table 7. Generic list of environmental data types that can be collected when undertaking a surfing EIA.

Surfing Break Component Schematics	Bathymetry Data (XYZ with Metadata, including Backscatter)	Bathymetry/Digital Elevation Models/ Digital Terrain Models	Suspended Sediment Concentrations
Topographic data (<i>e.g.</i> , contours, LIDAR data)	Hydrodynamic modeling of oceanographic conditions	Sediment grain size data	Wave data
Side scan images	Oblique photos of surfing waves	Video of surfing waves	Aerial photos showing shoreline position and wave refraction
Links to documents	Water quality data	Tidal data	Current data

* LIDAR = light detection and ranging.

acteristics around surfing breaks. Having information available from a GIS supports their mandate to protect surfing breaks and the rights of surfers to use surfing resources. Surfrider is currently working with the U.S. National Parks Service to locate all surfing breaks in national parks and collect information on the number of users (C. Nelsen, personal communication). In the current research, ArcGIS version 9.2 (Environmental Systems Research Institute Staff, 2006) was used as a core tool to process geographic information and to understand the case studies presented earlier. ArcGIS version 9.2 has also been used to process, store, interpret, and visualize information around surfing breaks by Scarfe (2008).

Linking to existing coastal data will be a critical part of a surfing GIS, and this has been made easier by the various sources of geographic information are now streamed over the Internet to GIS software. Figures 1, 5, 6, 2, and 17 all use information from either <http://www.geographynetwork.com> or <http://www.nztopoonline.linz.govt.nz> Internet map servers (ArcIMSs) during the construction of the geographic information or in the final figure. Another coastal management study involving a GIS has been implemented in Xiamen Bay, China, and Jiang *et al.* (2004) present a discussion on coastal GISs and clear GIS imagery that could be used in a surfing GIS, for example, geodatabasing of photography and incorporation of coastal numerical modeling.

The preceding techniques at the strategic and project level should be used in coastal plans to identify surfing break locations, the physical processes that cause the quality waves to form, and the threats to the wave quality. Early consultation and consideration of effects on surfing breaks is recommended not only to minimize conflict between parties but also to ensure that surfing amenities are recognized and optimized. In this context, surfing amenity is optimized by protecting against threats, as well as taking up opportunities to enhance surfing breaks where appropriate.

DISCUSSION

Historically there has tended to be a single-issue (*e.g.*, the protection of coastal real estate) or single-sector (*e.g.*, marine transportation) management approach applied in coastal engineering projects (*e.g.*, Jacobson and Rennie, 1991; Pilkey and Dixon, 1996). A lack of integrative participatory approaches has meant that those stakeholders without a strong political voice (Lazarow, Miller, and Blackwell, 2007b) have often been ignored in coastal management. The unplanned impacts to surfing amenities caused by coastal engineering are evidence that recreational surfers have been one of these stakeholder groups.

Negative responses to traditional coastal engineering practices are driving the development of integrated engineering methods that work with, rather than against, nature and that benefit multiple coastal user groups. Practices that take into account more than one objective and include visual amenity, biological enhancement, and recreational concerns will continue to develop. It is expected that as more detailed EIAs of coastal projects are undertaken, weaknesses in the use of traditional coastal engineering technology around surfing breaks will be highlighted and there will be an effort to include recreational surfing in engineering designs. As multiple objectives are taken into account, innovative and holistic engineering techniques such as wave rotating structures, submerged reefs, submerged groins, and stabilized artificial nourishment may be seen as preferable solutions to many coastal engineering problems. The artificial surfing reef concept (Black, 2001a, 2001b; Mead, 2001; Pratte *et al.*, 1989; Walker, Palmer, and Kukea, 1972) is an example of a coastal engineering technology that can minimize environmental effects by attempting to mimic natural processes and can benefit multiple coastal users. The ability to reproduce natural environments with artificial surfing reefs is still being tested (Scarfe, 2008).

During observations by the authors of various conflicts between development and surfing, it appears that authorities and developers often only consider serious investigations to impacts on surfing amenities as a reaction to environmental lobbying. This is contrary to ICZM principles, which require consultation with affected parties in the initial stages of development and a strategic rather than reactive approach to environmental effects. Surfers Against Sewage (United Kingdom; Wheaton, 2006), Surfrider (global), and the Surfbreak Protection Society (New Zealand) are examples of surfer-led groups that have developed to advocate surfers concerns due to a lack of strategic leadership from central and regional governments. Their causes would be greatly supported through the inclusion of surfing in coastal management in a strategic manner. The lack of historical advocacy for surfing is covered in Lazarow, Miller, and Blackwell (2007b).

To effectively include surfing amenities in ICZM, there needs to be legislative frameworks for considering surfers' objections to coastal activities. A regulatory approach is recommended generally for coastal management at various national and international levels by Goldberg (1994) to minimize conflict due to competing for coastal zone space. Goldberg (1994) suggests that regulation should also exist where there is currently no conflict in order to preempt possible future conflict. Spain was used as an example; 42% of the coast-

line (at time of publication) was unoccupied, and laws and policies had been formulated to minimize unregulated development. With the exception of the surfing reserves implemented by Farmer and Short (2007), no known regulatory techniques for managing issues around surfing breaks have been found in the literature. It is hoped that more examples of how to manage coastal management issues eventuate from New Zealand's proposed Coastal Policy Statement (Department of Conservation Staff, 2008) as it is implemented.

The Australian requirement for a surfing site to be a surfing reserve is that "recognised by the NSR-A and the local community for the quality and consistency of its surf and its long-term and on going relationship between the surf and surfers." (Farmer and Short, 2007, p. 100). The definition of a surfing reserve also extends to "the beach and adjacent surf zone . . . [and to] features that intrinsically enhance aspects of the surfing experience, including structures such as surf clubs or places considered sacred by surfers for a particular reason" (Farmer and Short, 2007, p. 100). Farmer and Short's (2007) definition of a surfing reserve could be extended to include wave breaking, preconditioning, and sheltering of a surfing break.

CONCLUSIONS

Case studies of surfing breaks that have been both improved and compromised by coastal development have been presented to illustrate the need to nurture fragile surfing resources. Impacts to surfing outlined using the case studies will continue to occur unless proper provisions in coastal management are made. This will be especially important to realize for protection of surfing in some counties where coastal management decisions are made based on economic rather than environmental effects. Surfing breaks could be too easily discounted from everyday decision making by short-term cost-benefit-based arguments for relatively high economic returns to a community result from major engineering works. However, the work of Lazarow and colleagues (Lazarow, 2007; Lazarow, Miller, and Blackwell, 2007a, 2007b) and Nelsen, Pendleton, and Vaughn (2007) show that the economic benefits of surfing breaks to coastal communities can be significant.

It has been proposed in this paper that the requirement of ICZM to balance the needs of various interest groups can be better achieved through innovative and nontraditional coastal engineering practices that provide multiple benefits to many users. The artificial surfing reef concept is used as an example of an engineering technique that can facilitate ICZM, and monitoring of such a structure is included in Scarfe, (2008). Another ICZM mechanism is the EIA process, which provides an avenue for surfers to address concerns relating the impacts of coastal developments on surfing breaks. To assist with the preparation of an EIA, various common activities that can affect the surfing wave quality are presented (Table 5), as well as a list of surfing and oceanographic factors (Table 6) and a list of environmental data types (Table 7). As part of this EIA process it is important to collect baseline information, and this is discussed further in Scarfe and Healy (2005) and Scarfe (2008).

For the best environmental result, recognition is required of surfing amenities as specific natural resources in coastal plans and environmental legislature to facilitate their protection and enhancement. For example, a coastal plan that identifies surfing break locations, the physical processes that cause the quality waves to form, and the threats to the wave quality gives greater weighting to any concerns that a coastal engineering project may jeopardize the surfing break. Early consultation and consideration of effects to surfing breaks is recommended not only to minimize conflict among parties but also to ensure that surfing amenities are maximized. In this context, surfing amenities are maximized by protecting against threats, as well as taking opportunities to enhance surfing breaks where appropriate.

LITERATURE CITED

- Anonymous, 2003. Working for a new ocean ethos: ocean activism on the shoreline—an interview with Christopher Evans. *Multi-national Monitor*, 24(9), 26.
- Bartlett, D. and Smith, J., 2005. *GIS for Coastal Zone Management*. Boca Raton, Florida: CRC Press, 310p.
- Battalio, B., 1994. Estimating breaking wave height at Ocean Beach, San Francisco. *Shore and Beach*, 62(4), 33–36.
- Beamsley, B. and Black, K.P., 2003. The effect of offshore reefs on inshore surfing conditions. In: Black, K.P., and Mead, S.T. (eds.), *Artificial Surfing Reefs 2003: The 3rd International Conference*. Raglan, New Zealand; CD Publication. pp. 99–114.
- Benedet, L.; Pierro, T., and Henriquez, M., 2007. Impacts of coastal engineering projects on the surfability of sandy beaches. *Shore and Beach*, 75(4), 3–20.
- Black, K.P., 1997. Wave Refraction Model WBEND. Occasional Report. Hamilton, New Zealand: University of Waikato, Department of Earth Sciences, Centre of Excellence in Coastal Oceanography and Marine Geology, 28p.
- Black, K.P., 2006. The 3DD Computational Marine and Freshwater Laboratory: Model WBEND. ASR Technical Series. Publisher: ASR Ltd, Raglan, New Zealand, 10p.
- Black, K.P., 2001a. Artificial surfing reefs for erosion control and amenity: theory and application. *Journal of Coastal Research*, Special Issue No. 34, pp. 1–14.
- Black, K.P. (ed.), 2001b. *Natural and Artificial Reefs for Surfing and Coastal Protection*. *Journal of Coastal Research*, Special Issue No. 29, 152p.
- Black, K.P. and Mead, S.T., 2001. Wave rotation for coastal protection. In: *Proceedings of the 2001 Coasts and Ports Conference* (Gold Coast, Australia), pp. 120–127.
- Black, K.P. and Mead, S.T., 2007. Sand bank responses to a multi-purpose reef on an exposed sandy coast. *Shore and Beach*, 75(4), 55–66.
- Black, K.P. and Rosenberg, M.A., 1992. Semi-empirical treatment of wave transformation outside and inside the breaker line. *Coastal Engineering*, 16, 313–345.
- Black, K.P.; Hutt, J.A., and Mead, S.T., 1998. Takapuna Boat Ramp: Surfing Impact Assessment and Reef Feasibility Study. Report for North Shore City Council, October 1998.
- Borrero, J.C. and Nelsen, C., 2003. Results of a comprehensive monitoring program at Pratte's Reef. In: Black, K.P., and Mead, S.T. (eds.), *Artificial Surfing Reefs 2003: The 3rd International Conference*. Raglan, New Zealand; CD Publication, pp. 83–98.
- Breman, J., 2002. *Marine Geography: GIS for the Oceans and Seas*. Redlands, California: ESRI Press, 224p.
- Bruce Brown Films, 1990. *Endless Summer*. DVD rerelease of 1964 surfing film. Torrance, California: Bruce Brown Films. 93 min.
- Buckley, R., 2002a. Surf tourism and sustainable development in the Indo-Pacific Islands: the industry and the islands. *Journal of Sustainable Tourism*, 10(5), 405–424.
- Buckley, R., 2002b. Surf tourism and sustainable development in the

- Indo-Pacific Islands: recreational capacity management. *Journal of Sustainable Tourism*, 10(5), 425–442.
- Buonaiuto, F.S. and Kraus, N.C., 2003. “Threes” an unusual surfing spot at Shinnecock Inlet, New York. *Shore and Beach*, 71(4), 7–12.
- Cearreta, A.; Monge, M.; Iriarte, E.; Uriarte, A., and Liria, P., 2005. Morphological Monitoring of Oka River Mouth and Urdaibai Estuary (Biosphere Reserve). Technical report. Bilbo, Spain: Universidad del Pais Vasco and AZTI-Tecnalia, 94p [in Spanish].
- Christensen, S. and Baker, M., 2007. Fish hooks in the marina decision. *Resource Management Journal*, April, 1–6.
- Cicin-Sain, B., 1993. Sustainable development and integrated coastal management. *Ocean and Coastal Management*, 29(1–3), 1–11.
- Dally, W.R., 1989. Quantifying beach “surfability.” In: *Proceedings of the Beach Technology Conference* (Tampa, Florida), pp. 47–58.
- Dally, W.R. and Osiecki, D.A., 2007. Sculpting beach nourishment to improve surfing. *Shore and Beach*, 75(4), 38–42.
- Department of Conservation Staff, 2008. Proposed New Zealand Coastal Policy State 2008. Wellington, New Zealand: Department of Conservation Policy Group, 35p.
- DHI Software Staff, 2003. *MIKE 21 NSW Near Shore Spectral Module User Guide: June 2003*. Hørsholm, Denmark: DHI Software.
- Environmental Systems Research Institute Staff, 2006. *ArcGIS 9: Using ArcGIS Desktop*. Software Manual. Redlands, California: ESRI, 435p.
- Farmer, B. and Short, A.D., 2007. Australian national surfing reserves: rationale and process for recognising iconic surfing locations. *Journal of Coastal Research*, Special Issue No. 50, pp. 99–103.
- French, P.W., 1997. *Coastal and Estuarine Management*. London: Routledge Environmental Management Series, 251p.
- Frihy, O.E., 2001. The necessity of environmental impact assessment (EIA) in implementing coastal projects: lessons learned from the Egyptian Mediterranean coast. *Ocean & Coastal Management*, 44(7–8), 489–516.
- George, S., 2004. When it comes to making waves, can Mother Nature compete with man’s “happy accidents?” *Surfer Magazine*, April, 130–137.
- Goldberg, E.D., 1994. *Coastal Zone Space: Prelude to Conflict?* Paris: UNESCO, 138p.
- Gorman, R.M., 2005. Numerical wave forecasting for the New Zealand region. In: Townsend, M. and Walker, D. (eds.), *Proceedings for Coasts and Ports Australasian Conference*, Adelaide, South Australia, pp. 179–184.
- Gorman, R.M.; Bryan, K.R., and Laing, A.K., 2003a. Wave hindcast for the New Zealand region: deep-water wave climate. *New Zealand Journal of Marine and Freshwater Research*, 37, 589–612.
- Gorman, R.M.; Bryan, K.R., and Laing, A.K., 2003b. Wave hindcast for the New Zealand region: nearshore validation and coastal wave climate. *New Zealand Journal of Marine and Freshwater Research*, 37, 567–588.
- Healy, T.R. and Wang, Y., 2004. Integrated coastal zone management for sustainable development: with comments on applicability to muddy coasts. *Journal of Coastal Research*, Special Issue No. 43, pp. 229–242.
- Healy, T.R.; Stephens, S.; Black, K.P.; Gorman, R.; Cole, R., and Beamsley, B., 2002. Port redesign and planned beach renourishment in a high wave energy sandy-muddy coastal environment, Port Gisborne, New Zealand. *Geomorphology*, 48, 163–177.
- Hume, T.M. and Herdendorf, C.E., 1993. On the use of empirical stability relationships for characterising estuaries. *Journal of Coastal Research*, 9(2), 413–422.
- Hutt, J.A., 1997. Bathymetry and Wave Parameters Defining the Surfing Quality of Five Adjacent Reefs. Hamilton, New Zealand: University of Waikato, Master’s thesis, 183p.
- Hutt, J.A.; Black, K.P., and Mead, S.T., 2001. Classification of surf breaks in relation to surfing skill. *Journal of Coastal Research*, Special Issue No. 29, pp. 66–81.
- Jacobson, M. and Rennie, H.G. 1991. Alternatives to hard engineering solutions for coastal management problems: options sensitive to cultural and environmental concerns. In: Bell, R.G.; Hume, T.M., and Healy, T.R. (eds.), *Proceedings for 10th Australasian Conference on Coastal and Ocean Engineering* (Auckland, New Zealand). Hamilton, New Zealand; Water Quality Centre Publication No. 21, pp. 323–328.
- Jiang, Y.W.; Wai, O.W.H.; Hong, H.S., and Li, Y.S., 2004. A geographical information system for marine management and its application to Xiamen Bay, China. *Journal of Coastal Research*, Special Issue No. 43, pp. 254–264.
- Kapua, P., 2007. Review of the role of Maori under the Resource Management Act 1991. *Resource Management Theory & Practice*, 2007, 92–109.
- Kilpatrick, D., 2005. Determining Surfing Break Components at Aramoana Beach, Dunedin. Dunedin, New Zealand: University of Otago, postgraduate diss., 68p.
- Kiwi Surf Staff, 2007. Whangamata Bar carnage. *Kiwi Surf Magazine*, 99, 22.
- Klein, A.H.F.; Santana, G.G.; Diehl, F.L., and de Menezes, J.T., 2003. Analysis of hazards associated with sea-bathing: results of five years work in oceanic beaches of Santa Catarina State, Southern Brazil. *Journal of Coastal Research*, Special Issue No. 35, pp. 107–116.
- Lazarow, N., 2007. The value of coastal recreational resources: a case study approach to examine the value of recreational surfing to specific locales. *Journal of Coastal Research*, Special Issue No. 50, pp. 12–20.
- Lazarow, N.; Miller, M.L., and Blackwell, B., 2007a. Dropping in: a case study approach to understanding the socio-economic impact of recreational surfing and its value to the tourism industry. In: *Proceedings of the 5th International Coastal and Marine Tourism Congress* (Auckland, New Zealand), pp. 448–461.
- Lazarow, N.; Miller, M.L., and Blackwell, B., 2007b. Dropping in: a case study approach to understanding the socioeconomic impact of recreational surfing and its value to the coastal economy. *Shore and Beach*, 75(4), 21–31.
- Lee, N., 1989. *Environmental Impact Assessment: A Training Guide*, 2nd edition. Occasional Paper 18. Manchester, United Kingdom: University of Manchester, Department of Planning and Landscape.
- Longhorn, R.A., 2005. Coastal Spatial Data Infrastructure. In: Bartlett, D., and Smith, J. (eds.), *GIS for Coastal Zone Management*. Boca Raton, Florida: CRC Press Ltd, ISBN 0-415-319-722, pp.1–16.
- Mack, I.D., 2003. Quantitative Assessment of the Surfability of Pratte’s Artificial Surfing Reef Santa Monica Bay, CA. Los Angeles, California: University of Southern California, Master’s thesis, 111p.
- Mather, J. and Rennie, H., 1997. Case study: Whangamata Harbor. In: Stokes, E., and Begg, M. (eds.), *Te Hononga ki te Whenua. Belonging to the Land: People and Places in the Waikato Region*. Hamilton, New Zealand: NZ Geographical Society, Geoff BurrIDGE Memorial Publication, Waikato Branch, pp. 98–102.
- McHarg, I.L., 1969. *Design with Nature*. Garden City, New York: Natural History Press, 197p.
- Mead, S.T., 2001. Incorporating High-Quality Surfing Breaks into Multi-Purpose Reefs. Hamilton, New Zealand: University of Waikato, Ph.D. thesis, 213p.
- Mead, S.T. and Black, K.P., 2001a. Field studies leading to the bathymetric classification of world-class surfing breaks. *Journal of Coastal Research*, Special Issue No. 29, pp. 5–20.
- Mead, S.T. and Black, K.P., 2001b. Functional component combinations controlling surfing quality at world-class surfing breaks. *Journal of Coastal Research*, Special Issue No. 29, pp. 21–32.
- Mead, S.T. and Black, K.P., 2001c. Predicting the breaking intensity of surfing waves. *Journal of Coastal Research*, Special Issue No. 29, pp. 51–65.
- Mead, S.T. and Phillips, D., 2007. Temporal and spatial variation of a large offshore sandbar at Raglan, NZ. In: *Proceedings of the 2007 Coasts and Ports Australasian Conference* (Gold Coast, Queensland). CD Publication, 6p.
- Mead, S.T.; Black, K.P., and Moores, A., 2007. Mount Maunganui Reef: amalgamating design and the constraints of construction. In: *Proceedings of the 2007 Coasts and Ports Australasian Conference* (Gold Coast, Australia). CD Publication, 6p.
- Mead, S.T.; Black, K.P., and Scarfe, B., 2004. Review of the Palm

- Beach Protection Strategy. Prepared for Save Our Surf Incorporated, May 2004, 32p + appendices.
- Mead, S.T.; Black, K.P.; Scarfe, B.E., and Frazerhurst, J., 2003. The effect of wave focusing on surfing site selection and design at scales of intercontinental shelf to sub-tidal reef. In: Black, K.P., and Mead, S.T. (eds.), *Artificial Surfing Reefs 2003: The 3rd International Conference*. Raglan, New Zealand; CD Publication, pp. 115–137.
- Mead, S.T.; Borrero, J.C.; Black, K.P.; Anderson, D., and Frazerhurst, J., 2007. Multi-faceted beach management at St. Francis Bay Beach, South Africa: “Endless Summer III.” *Shore and Beach*, 75(4), 43–54.
- Moore, A., 2001. Using Video Images to Quantify Wave Sections and Surfer Parameters. Hamilton, New Zealand: University of Waikato, Master’s thesis, 143p.
- Morgan, R.K., 1998. *Environmental Impact Assessment: A Methodological Perspective*. London: Kluwer, 307p.
- Nelsen, C. and Howd, P., 1996. Surf as coastal resource: the wave of the future. *Geotimes*, December, 19–22.
- Nelsen, C. and Rauscher, M., 2002. Effective use of volunteer resources: GIS in community activism. In: Breman, J. (ed.), *Marine Geography: GIS for the Oceans and Seas*. Redlands, California: ESRI Press, pp. 121–126.
- Nelsen, C.; Pendleton, L., and Vaughn, R., 2007. A socioeconomic study of surfers at Trestles Beach. *Shore and Beach*, 75(4), 32–37.
- Phillips, D.J., 2004. Sediment Dynamics of a Shallow Exposed Surfing Headland. Hamilton, New Zealand: University of Waikato, Ph.D. thesis, 269p.
- Pilkey, O.H. and Dixon, K.L., 1996. *The Corps and the Shore*. Washington, D.C.: Island Press, 274p.
- Polette, M. and Raucii, G.D., 2003. Methodological proposal for carrying capacity analysis in sandy beaches: a case study at the central beach of Balneario Camboriu (Santa Catarina, Brazil). *Journal of Coastal Research*, Special Issue No. 35, pp. 94–106.
- Pratte, T.P., 1987. Ocean wave recreation. In: *Proceedings for Coastal Zone '87* (Seattle, Washington), pp. 5386–5398.
- Pratte, T.P.; Walker, J.R.; Gadd, P.E., and Leidersdorf, C.B., 1989. A new wave on the horizon: towards building surfing reefs near-shore. In: *Proceedings for Coastal Zone '89* (Charleston, South Carolina), pp. 3403–3411.
- Quinn, P.J., 2007. Whangamata: worlds in collision. *New Zealand Geographic*, September–October (87), 54–69.
- Raichle, A.W., 1998. Numerical predictions of surfing conditions at Mavericks, California. *Shore and Beach*, 66(2), 26–30.
- Rennie, H.G., 2000. Coastal fisheries and marine planning in transition. In: Memon, P.A., and Perkins, H.C. (eds.), *Environmental Planning and Management in New Zealand*. Palmerton North, New Zealand: Dunmore Press, pp. 215–222.
- Rennie, H.G., 2003. A geography of marine farming rights in New Zealand: some rubbings of patterns on the face of the sea. Hamilton, New Zealand: University of Waikato, Ph.D. thesis, 405p.
- Resource Management Act, 1991. New Zealand.
- Sayce, A.J., 1997. Transformation of Surfing Waves on Steep and Complex Reefs. Hamilton, New Zealand: University of Waikato, Master’s thesis, 158p.
- Scarfe, B.E., 2002a. Categorising Surfing Manoeuvres Using Wave and Reef Characteristics. Hamilton, New Zealand: University of Waikato, Master’s thesis, 181p.
- Scarfe, B.E., 2002b. Measuring water level corrections (WLC) Using RTK GPS. *Hydrographic Journal*, 104, 17–23.
- Scarfe, B.E., 2008. Oceanographic Considerations for the Management and Protection of Surfing Breaks. Hamilton, New Zealand: The University of Waikato, Ph.D. thesis, 307p + appendices. <http://adt.waikato.ac.nz/public/adt-uow20080806.195651/index.html> (accessed October 9, 2008).
- Scarfe, B.E.; Healy, T.R., and Rennie, H.G., 2009. Research-based surfing literature for coastal management and the science of surfing: a review. *Journal of Coastal Research*, 25(3), 539–557.
- Scarfe, B.E.; Elwany, M.H.S.; Black, K.P., and Mead, S.T., 2003a. Categorizing the Types of Surfing Breaks around Jetty Structures. Scripps Institution of Oceanography Technical Report, 8p. <http://repositories.cdlib.org/sio/techreport/18/> (accessed August 6, 2008).
- Scarfe, B.E.; Elwany, M.H.S.; Black, K.P., and Mead, S.T., 2003b. Surfing Conditions Around Jetties. Scripps Institution of Oceanography Technical Report, 92p. + appendices. <http://repositories.cdlib.org/sio/techreport/10> (accessed August 6, 2008).
- Shand, T.D.; Reinen-Hamill, R.A.; Shand, R.D., and Viljoen, W., 2007. Empirical modeling of run-up and overtopping at a Boulder Beach, Raglan, New Zealand. In: *Proceedings of the 2007 Coasts and Ports Australasian Conference* (Gold Coast, Queensland). CD Publication, 6p.
- Sheffield, A.T., 1991. The Sedimentology and Hydrodynamics of Whangamata Harbor. Hamilton, New Zealand: University of Waikato, Master’s thesis, 180p.
- Sheffield, A.T.; Healy, T.R., and McGlone, M.S., 1995. Infilling rates of a steepland catchment estuary, Whangamata, New Zealand. *Journal of Coastal Research*, 11(4), 1294–1308.
- Small, C. and Nicholls, R.J., 2003. A global analysis of human settlement in coastal zones. *Journal of Coastal Research*, 19(3), 584–599.
- Spiers, K.C., 2005. Continued Beach Renourishment from Dredge Spoil Disposal. Hamilton, New Zealand: University of Waikato, Department of Earth Sciences, Master’s thesis, 241p + appendices.
- Spiers, K.C. and Healy, T.R., 2007. Beach renourishment through spoil disposal downdrift of a dredged entrance channel. In: Kraus, N.C., and Rosati, J. D. (eds.), *Coastal Sediments '07*. Reston, Virginia: ASCE, pp. 2358–2371.
- Thomson, J., 2003. Coastal Values and Beach Use Survey Report. Hamilton, New Zealand: Environment Waikato Technical Report 2003/09, 183p.
- Tiwi, D.A., 2004. *Improving Environmental Impact Assessment for Better Integrated Coastal Zone Management*. Leiden, the Netherlands: A.A. Balkema Publishers, 234p.
- Tomlinson, R.; Mcgrath, J.; Jackson, L.A.; Stuart, G.; Robertson, A.; Dagata, M., and Corbett, B., 2003. Processes to develop an integrated and multifunctional coastal management strategy for Palm Beach, Gold Coast. In: *Proceedings of the 2003 Coasts and Ports Conference* (Auckland, New Zealand), CD Publication, paper 67.
- United Nations, 1992. *Agenda 21*.
- Vaughan, G., 2005. Simulating Breaking Waves Using SPH. Hamilton, New Zealand: University of Waikato, Ph.D. thesis, 203p.
- Walker, J.R., 1974. Recreational Surfing Parameters. LOOK Laboratory Technical Report 30. Honolulu: University of Hawaii, Department of Ocean Engineering, 311p.
- Walker, J.R. and Palmer, R.Q., 1971. Surf Parameters: A General Surf Site Concept. LOOK Laboratory Technical Report No. 18. Honolulu: University of Hawaii, Department of Ocean Engineering, 48p.
- Walker, J.R.; Palmer, R.Q., and Kukea, J.K., 1972. Recreational Surfing on Hawaiian Reefs. In: *Proceedings of the 13th Coastal Engineering Conference* (Vancouver, British Columbia, Canada), pp. 2609–2628.
- Whangamata Marina Society Staff, 1995. Proposed Whangamata Marina: Assessment of Environmental Effects and Resource Consents. Prepared by Works Consultancy Services.
- Wheaton, B., 2007. Identity, politics, and the beach: environmental activism in Surfers Against Sewage. *Leisure Studies*, 26(3), 279–302.
- Wheeler, P.J. and Peterson, J., 2007. Long-term morphological change at an engineered coastal lagoon entrance: an appraisal using GIS depth shading techniques. In: *Proceedings of the 2007 Coasts and Ports Australasian Conference* (Gold Coast, Queensland). CD Publication, 6p.
- Willis, C.M. and Griggs, B.G., 2003. Reductions in fluvial sediment discharge by coastal dams in California and implications for beach sustainability. *Journal of Geology*, 111, 167–182.
- Wood, C., 2003. *Environmental Impact Assessment: A Comparative Review*, 2nd edition. Harlow, United Kingdom: Pearson Education, 405p.
- Wright, L.D. and Short, A.D., 1984. Morphodynamic variability of surf zones and beaches: a synthesis. *Marine Geology*, 56, 93–118.
- Wright, D.J.; Blongewicz, M.J., and Halpin, P.N., 2007. *Arc Marine: GIS for a Blue Planet*. Redlands, California: ESRI Press, 216p.